

TELEDYNE HASTINGS INSTRUMENTS



INSTRUCTION MANUAL

MASS FLOWMETER CONTROLLER READOUT PowerPod-100



TELEDYNE INSTRUMENTS
Hastings Instruments
A Teledyne Technologies Company

Manual Print History

The print history shown below lists the printing dates of all revisions and addenda created for this manual. The revision level letter increases alphabetically as the manual undergoes subsequent updates. Addenda, which are released between revisions, contain important change information that the user should incorporate immediately into the manual. Addenda are numbered sequentially. When a new revision is created, all addenda associated with the previous revision of the manual are incorporated into the new revision of the manual. Each new revision includes a revised copy of this print history page.

Revision A (Document Number 161-052005)..... May 2005
Revision B (Document Number 161-022007)..... Feb. 2007



Visit www.teledyne-hi.com for WEEE disposal guidance.



CAUTION: The **POWERPOD-100** is designed for **INDOOR** operation only.

Hastings Instruments reserves the right to change or modify the design of its equipment without any obligation to provide notification of change or intent to change.

Table of Contents

1	GENERAL INFORMATION.....	4
1.1	DESCRIPTION.....	4
1.2	SPECIFICATIONS.....	4
2	INSTALLATION AND WIRING.....	5
2.1	INSTALLATION.....	5
2.2	PANEL MOUNTING THE POWERPOD-100.....	5
2.3	WIRING.....	5
	<i>Fig. 1 Front Panel View</i>	6
	<i>Fig. 2 Rear Panel View</i>	6
	<i>Fig. 3 I/O Wiring Diagram</i>	7
	<i>Fig. 4 Alarm Circuit</i>	8
3	SWITCH & FUNCTION DEFINITIONS.....	9
3.1	SWITCH DEFINITIONS.....	9
3.2	MODE SWITCH (S1).....	9
3.3	STEP AND MIN-MAX SWITCH (S3).....	10
3.4	ZERO AND EXIT SWITCH (S4).....	10
3.5	CAL SWITCH (S5).....	10
	THE MODE SWITCH (S1), CYCLES THROUGH THE FOLLOWING FUNCTIONS.....	10
3.6	SET POINT (STPT).....	10
3.7	SET POINT HIGH 1 (SPH1).....	10
3.8	SET POINT LOW 1 (SPL1).....	11
3.9	SET POINT HIGH 2 (SPH2).....	11
3.10	SET POINT LOW 2 (SPL2).....	11
3.11	HYSTERESIS HIGH (HH).....	11
3.12	HYSTERESIS LOW (HL).....	11
3.13	FS CAL.....	11
3.14	DECIMAL POINT (DP).....	12
	THE STEP AND MIN-MAX RECALL SWITCH (S3) IS USED TO MOMENTARILY DISPLAY THE MAX (HI) AND THE MIN(LO) VALUES DISPLAYED. SWITCH S3 MUST BE USED WITHOUT FIRST DEPRESSING MODE (S1). IF S1 IS DEPRESSED FIRST, S3 TAKES ON THE STEP FUNCTION.....	12
3.15	MIN/MAX RECALL (HI/LO).....	12
4	OPERATING INSTRUCTIONS.....	13
4.1	TURN-ON INSTRUCTIONS.....	13
4.2	PROGRAM INSTRUCTIONS.....	13
5	CALIBRATION INSTRUCTIONS.....	15
5.1	CALIBRATION INSTRUCTIONS.....	15
5.2	USING A CALIBRATED FLOW METER/CONTROLLER.....	15
5.3	USING A PRECISION POWER SUPPLY.....	16
5.4	POWERPOD-100 RS232 COMMUNICATION PROTOCOL.....	18
6	WARRANTY.....	19
6.1	WARRANTY REPAIR POLICY.....	19
6.2	NON-WARRANTY REPAIR POLICY.....	19

1

General Information

1.1 Description

The model POWERPOD-100 is a microprocessor-based digital indicator capable of interfacing directly to a mass flowmeter/controller. An integrated ± 15 VDC @ 250 mA power supply is available providing a well regulated, short circuit and thermal overload protected output. It is packaged in a small 1/8 DIN, 5.5" deep extruded aluminum housing which provides excellent EMI/RFI shielding and good heat dissipation characteristics.

The POWERPOD-100 is a state-of-the-art product and uses the latest surface mount components. The internal microprocessor provides the following capabilities.

Push-button Zero and Full Scale Calibration

Front Panel Setup of Flowmeter/Controller control voltage (0-5 VDC, 0-10 VDC)

Front Panel Setup of (2) High and (2) Low Digital Set-points with open collector outputs.

1.2 Specifications

Signal Input:	0-5 VDC, 0-10 VDC
Input Resistance:	> 1 Megohm
Input Bias Current:	< 1 nA
Display Type:	0.4" high efficiency red LED's
Max display range:	$\pm 99,999$
A/D resolution:	$\pm 19,999$ counts
Linearity:	$\pm 0.01\%$ FS ± 1 count
FS Accuracy:	$\pm 0.01\%$ FS ± 1 count
FS Step Response	500 ms (typ)
Over-range Display	Flashing digits for input > 5.5 VDC
No Sensor Indication:	Flashing digits
Flowmeter Set-point Output:	0-5 VDC / 0-10 VDC
Flowmeter Power Supply:	± 15 VDC $\pm 5\%$ @ 250 mA (min)
Operating range:	+5° to +50°C
Input Power:	100, 115, and 230 VAC (solder pad jumper selectable)
Package dimensions:	3.78W x 1.89H x 5.1"D

2

Installation and Wiring

2.1 Installation

The POWERPOD-100 model enclosure is designated for panel mounting in a 1/8 DIN cutout. The cutout dimensions are shown below.

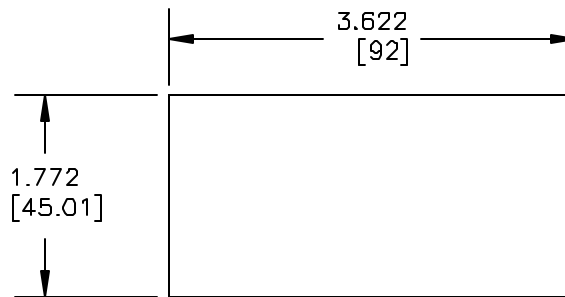

2.2 Panel mounting the POWERPOD-100

To mount the POWERPOD-100 to a panel, perform the following steps.

1. Rotate the four pawl screws (outside screws in each corner) several turns counter-clockwise to retract the pawls. Make sure the pawls retract enough to clear the back of the mounting panel. The pawls may be retracted to accommodate panel thickness up to 0.25 inches (6.35mm)
2. Insert the instrument into the panel cutout.
3. Position the pawls so that their elongated dimensions overlap the panel cutout and then tighten the screws. Do not over-tighten.
4. Installation complete.

2.3 Wiring

Reference Figures 3 and 4 for TRANSDUCER and INPUT/OUTPUT (I/O) wiring information. Power is applied with a 3-prong AC power cord. The instrument is protected by 250 V, 500 mA, time-delay, 5 mm fuse. The fuse holder is an integral part of the input power connector. A spare fuse is provided in the fuse holder. Internal solder jumpers are provided to allow 100, 110, or 240 VAC operation.

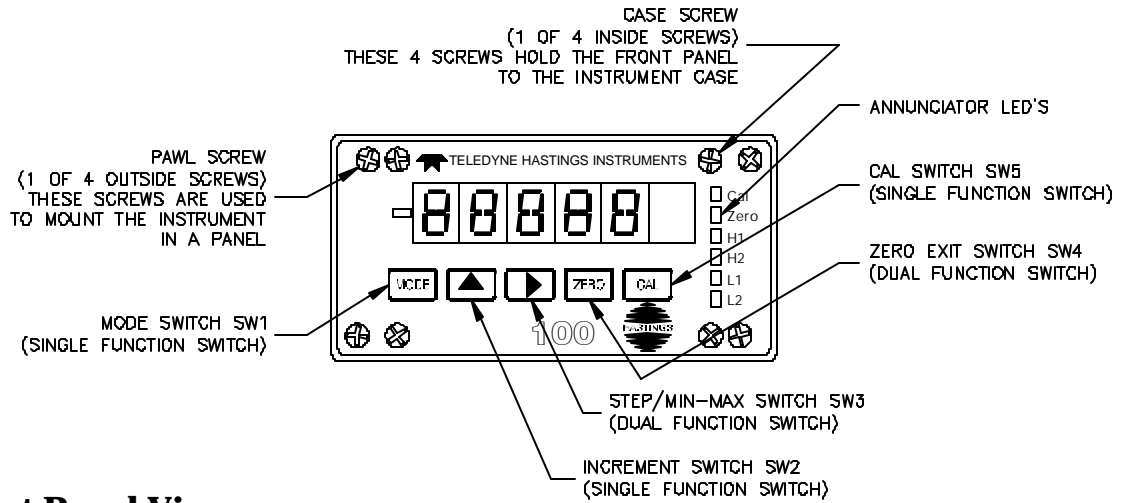

Fig. 1 Front Panel View

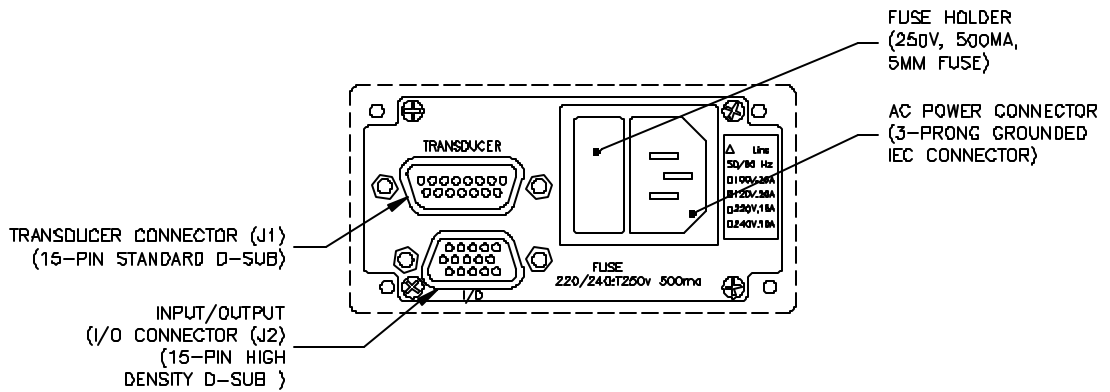

Fig. 2 Rear Panel View

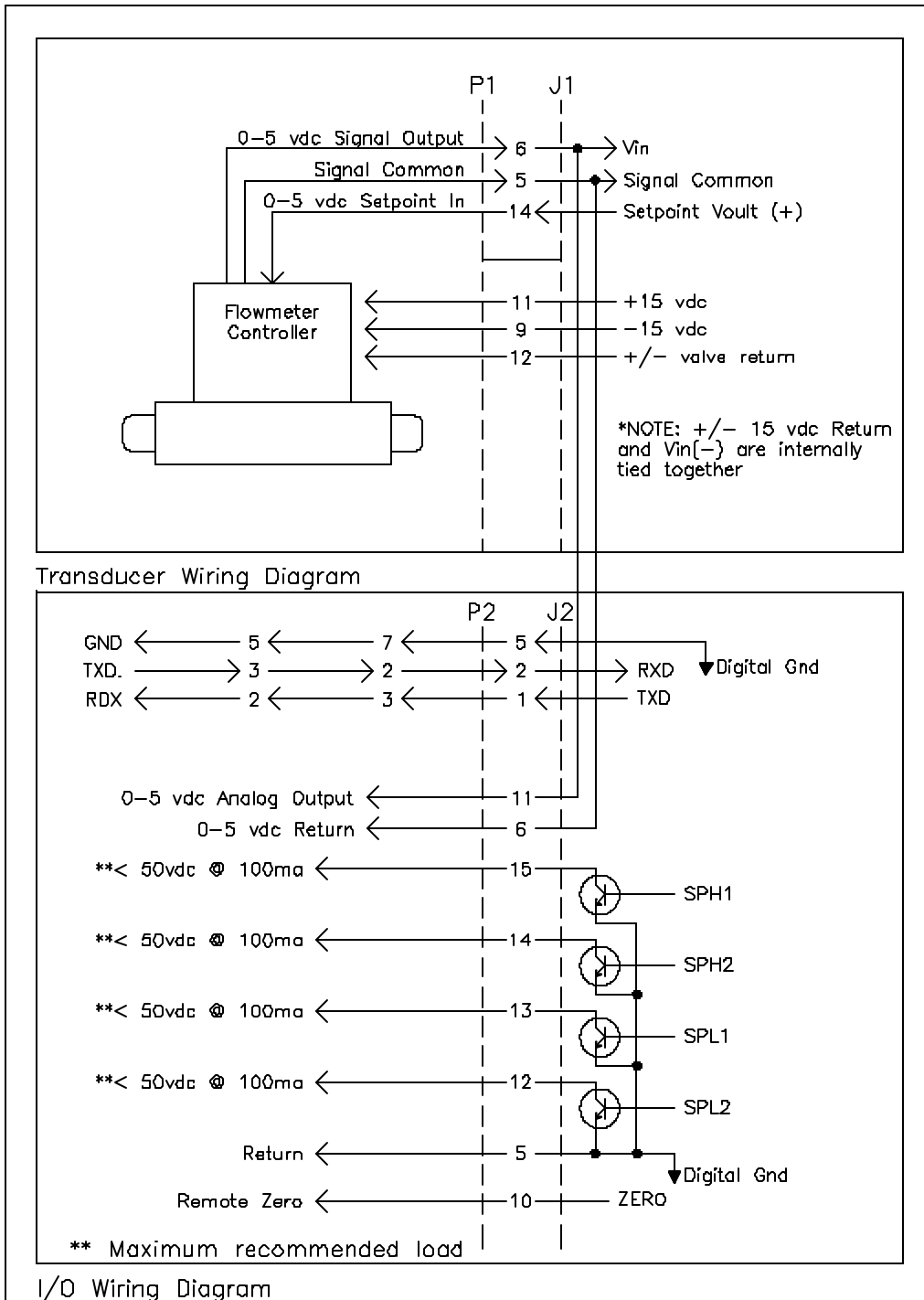

Fig. 3 I/O Wiring Diagram

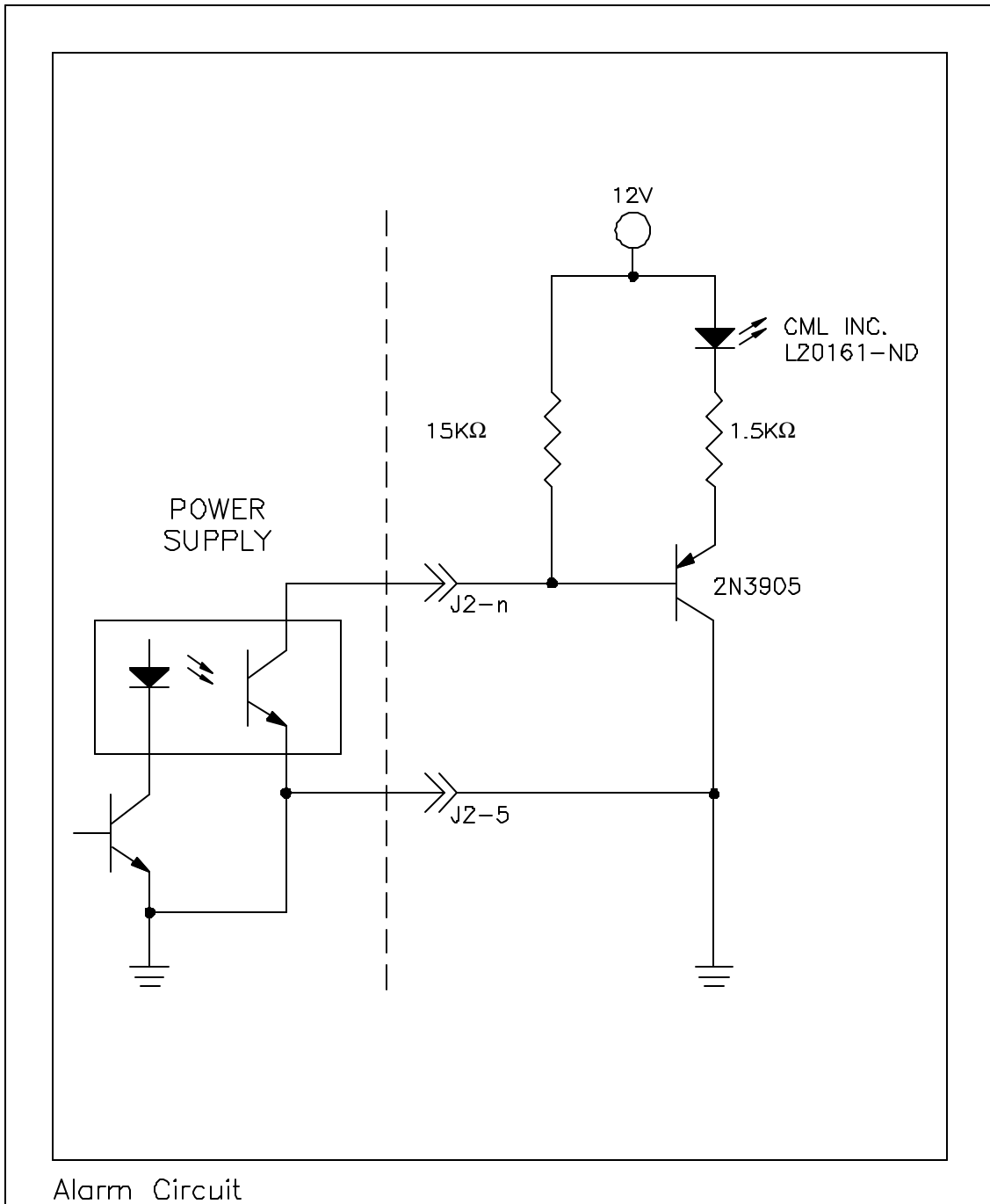
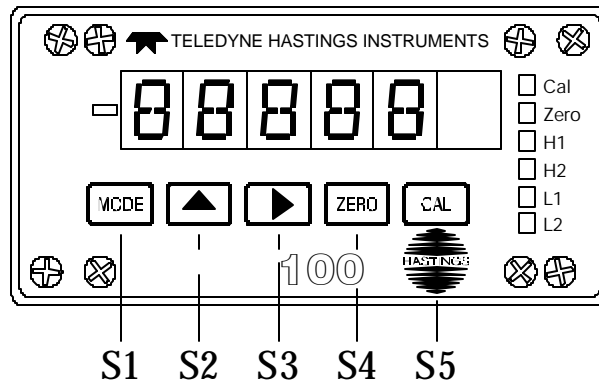

Fig. 4 Alarm Circuit

3 Switch & Function Definitions

3.1 Switch Definitions



3.2 Mode Switch (S1)

The Mode switch (S1) is used to cycle through the various setpoints, Hysteresis, calibration values and decimal point locations. The sequence is as follows. The designators, in parenthesis, identify text that will be displayed, momentarily, followed by the value.

Set point for Flow	(StPt)
Set Point High 1	(SPH1)
Set Point Low 1	(SPL1)
Set Point High 2	(SPH2)
Set Point Low 2	(SPL2)
Hysteresis High	(HH)
Hysteresis Low	(HL)
Cal	(CAL)
Decimal Point	(dP)
Exit	

While in the Mode Selection sequence, the indicator is no longer monitoring the input signal. To exit at any time, simply depress S4. All new data entered prior to exiting, except StPt, will be stored in non-volatile memory and recalled at power on. The StPt value is retained in static RAM and valid only while power to the unit is maintained. At power turn on the value of StPt defaults to 0000 and the Setpoint output voltage will be approximately -0.5 vdc.

3.3 Step and Min-Max Switch (S3)

This switch has a dual function. When in the MODE sequence, it steps the digit to be incremented, one position to the right. Using S3 in conjunction with S2 allows rapid updating of all parameter values. When not in the MODE sequence, depressing S3 displays the HI (Max) and LO (Min) readings, momentarily. These values are stored in static RAMS and are reset when power is applied.

3.4 Zero and Exit Switch (S4)

This switch has a dual function. When not in the MODE sequence, this switch must be depressed and held for approximately 3 seconds before it zeroes the reading on the display. The ZERO annunciator on the front panel should be illuminated. ZEROing is accomplished by storing the reading just prior to ZEROing and subtracting this value from all subsequent readings. This value is retained in non-volatile memory and recalled when power is applied. It is also used to compensate the StPt control voltage output.

When in the MODE sequence, this switch is used to exit. All values entered prior to exiting, except for the StPt value, will be retained in non-volatile memory and recalled when power is applied.

3.5 Cal Switch (S5)

This button has been disabled to prevent the user from mis-calibrating the unit.

Reference the PROGRAM INSTRUCTIONS, page 13 section 4.2, the FS Cal value, section 3.13 and the CALIBRATION INSTRUCTIONS, page 15 sections 5.1 through 5.3 for more information.

The Mode switch (S1), cycles through the following functions.

3.6 Set point (StPt)

The Setpoint (0-5 vdc) command signal used to control the flow through a Flowmeter controller. The output voltage is 0-5 vdc. The set point output is defined as:

$$\text{Setpoint Output} = \text{StPt} / \text{CAL} \times 5.000 \text{ vdc} \pm V_{\text{offset}}$$

Where V_{offset} = Flowmeter Output Offset voltage

Example: If the CAL value was programmed to be 7500 sccm and the desired flow rate is 5000 sccm, enter 5000 for the StPt value. Depress the ZERO switch to exit the MODE sequence and the Setpoint Output voltage will be 3.333 vdc. This is assuming the flowmeter output had no offset voltage.

3.7 Set Point High 1 (SPH1)

SPH1 is a digital Setpoint being constantly compared with the displayed reading. If the magnitude and sign of the reading exceeds the SPH1 value, the SPH1 open collector output will activate and pull its respective D-Sub connector pin to ground (Ref Figure 4 on page 4). The front panel LED (H1) will also illuminate. If SPH1 is exceeded, the reading must then drop below SPH1 less the Hysteresis High (HH) value before the open collector output opens and the H1 LED turns off.

3.8 Set Point Low 1 (SPL1)

SPL1 is another digital set point being constantly compared with the displayed reading. If the magnitude and sign of the displayed reading is less than the SPL1 value, the SPL1 open collector output will activate and LED (L1) will illuminate. If the displayed reading drops below SPL1, it must then exceed SPL1 plus the Hysteresis Low (HL) value before the open collector output opens and the L1 LED turns off.

3.9 Set Point High 2 (SPH2)

SPH2 is independent and functions identically to SPH1. SPH2 has its own open collector outputs and front panel LED (H2).

3.10 Set Point Low 2 (SPL2)

SPL2 is independent and functions identically to SPL1. SPL2 has its own open collector outputs and front panel LED (L2).

3.11 Hysteresis High (HH)

HH is the Hysteresis value for SPH1 and SPH2. The Hysteresis value determines the number of counts the displayed reading must fall below SPH1 and SPH2 values before deactivating their respective open collector outputs and LED's. The maximum value of Hysteresis is 99 counts while the minimum is 00 counts.

3.12 Hysteresis Low (HL)

HL is the Hysteresis value for SPL1 and SPL2. The Hysteresis value determines the number of counts the displayed reading must exceed the SPL1 and SPL2 values before deactivating their respective open collector outputs and LED's. The maximum value of Hysteresis is 99 counts while the minimum is 00 counts.

3.13 FS Cal

This input allows the user to set the full scale readout to any desired value. This input must be set to its desired value prior to performing the calibration. (See sections 5.1, 5.2 and 5.3). Once this value is changed, the calibration procedure must be completed before the change can take affect. It is recommended that the user change this value using a computer with a serial COM port (RS-232) and follow up with the procedures outlined in the CALIBRATION INSTRUCTIONS, sections 5.1 through 5.3.

The FS Cal number may be any number from 1 to 99999. Zero is an invalid FS Cal number. For best resolution and stability, choose a CAL number between 2000 and 19000 counts.

Example: If the Flowmeter is to be calibrated at a full scale flow rate of 500 sccm, the FS Cal value could be 500.00, 500.0 or 500. If the FS Cal value of 500.00 is used, the unit will automatically count by 3 when full scale calibration is completed since the analog-to-digital converter resolution is only 19,999 counts. Choosing a FS Cal value of 500.0 or 500 assures the best resolution and stability in this particular case.

3.14 Decimal Point (dP)

dP allows selection of decimal point locations for display. The locations selectable are x.xxxx, xx.xxx, xxx.xx, xxxx.x and xxxxx.

The STEP and MIN-MAX RECALL switch (S3) is used to momentarily display the MAX (HI) and the MIN(LO) values displayed. Switch S3 must be used without first depressing MODE (S1). If S1 is depressed first, S3 takes on the STEP function.

3.15 Min/Max Recall (HI/LO)

The HI and LO values are the maximum and minimum values, respectively, of the displayed readings. Sign and magnitude are constantly compared with the displayed readings at the instrument update rate of 2.5 times per second. The HI and LO values are retained in static RAM and are lost if power to the instrument is removed. When power is applied, the maximum value is initialized to -99,999 and the minimum value to 99.999.

4

Operating Instructions

4.1 TURN-ON INSTRUCTIONS

Reference Figures 3 and 4 for proper input and output signal wiring.

1. Apply power to the instrument.
2. Verify the instrument readout blanks momentarily, then displays the value of the input signal, display blinks if input floating.
3. To clear the StPt register, depress the MODE (S1), then the ZERO (S4) switch prior to using the instrument.

4.2 PROGRAM INSTRUCTIONS

Five front panel switches (S1, S2, S3, S4 and S5) allow the user to program Flowmeter Setpoint Output Voltage (StPt), Digital Setpoints (SPH1, SPL1, SPH2 and SPL2), Hysteresis (HH and HL), Calibration Number (CAL) and Decimal Points (dP) and monitor minimum, maximum or real time values.

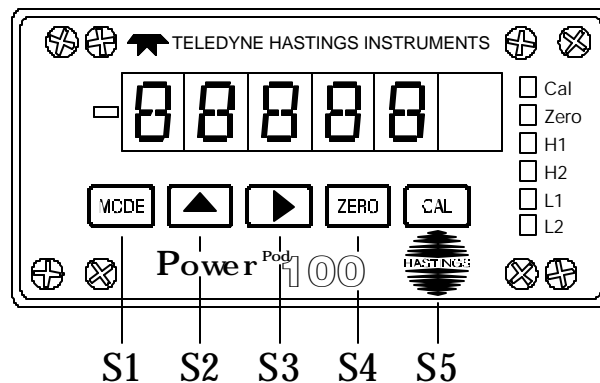

1. Depress MODE (S1) switch once.

The text StPt will be displayed momentarily followed by the current value for the Flowmeter Set point. Use switches S2 and S3 to set the StPt value. Proceed to Step 2 to set Set Point H1 (SPH1) or depress S4 to exit the MODE sequence. If S4 is depressed the latest StPt value is used to generate a new Flowmeter Setpoint output voltage.

2. Depress MODE (S1) switch once.

The text SPH1 followed by the current value of Set Point High 1 (SPH1) will be displayed. Use S2 and S3 to set SetPoint High 1 to the desired value. Proceed to Step 3 to set Setpoint Low 1 (SPL1) or depress S4 to exit MODE sequence. If S4 is depressed, the new value for SPH1 will be saved in non-volatile NOVRAM memory.

3. Depress MODE (S1) switch once.

The text SPL1 followed by the current value of Set Point Low 1 will be displayed. Repeat Step 2 to set SetPoint Low 1 to the desired value. Proceed to Step 4 or depress S4 to exit.

4. Depress MODE (S1) switch once

The text SPH2 followed by the current value of Set Point High 2 will be displayed. Repeat Step 2 to set SetPoint High 2 to the desired value. Proceed to Step 5 or depress S4 to exit.

5. Depress MODE (S1) switch once.

The text SPL2 followed by the current value of Set Point Low 2 will be displayed. Repeat Step 2 to set SetPoint Low 2 to the desired value. Proceed to Step 6 or depress S4 to exit.

6. Depress MODE (S1) switch once.

The text HH followed by the current value of Hysteresis High will be displayed. Repeat Step 2 to set Hysteresis High to the desired value. The maximum value for HH is 99 counts. Proceed to Step 7 or depress S4 to exit.

7. Depress MODE (S1) switch once.

The text HL followed by the current value of Hysteresis Low will be displayed. Repeat Step 2 to set Hysteresis Low to the desired value. The maximum value for HL is 99 counts. Proceed to Step 8 or depress S4 to exit.

8. Depress MODE (S1) switch once.

The text CAL followed by the current CAL number will be displayed. Repeat Step 2 to set the CAL number. Proceed to Step 9 or depress S4 to exit.

9. Depress MODE (S1) switch once.

The text dP followed by the current decimal position will be shown flashing. Use S2 to set the decimal point to the desired location.

10. Depress MODE (S1) switch once.

The instrument will exit the Mode Selection Sequence and enter the normal operating mode (i.e. monitoring the input signal).

This is the end of the PROGRAM INSTRUCTIONS.

5

Calibration Instructions

5.1 Calibration Instructions

The **POWERPOD-100** comes calibrated from the factory and should require no further adjustment by the customer. The ability of the customer to reset the display value at full scale signal input (5 or 10 volts) using the front panel, has been defeated. Any recalibration of the unit can only be accomplished using a computer with serial communication capability (RS-232). Connectors are supplied with which to construct a serial communication cable for the purpose of remotely controlling the **POWERPOD-100**. Consult the RS-232 wiring diagram in the **POWERPOD-100** manual.

Prior to connecting the **POWERPOD-100** to the flow-meter/controller, verify that the controller's $\pm 15\text{VDC}$ requirement is no more than 250 ma. The **POWERPOD-100** is capable of supplying up to 500ma for short periods of time (1/2 or 1 hour increments), but long term operation at loads greater than 250 ma may shorten the life of the instrument.

Calibration of the **POWERPOD-100** may be performed using either an appropriately calibrated flow-meter/controller or a precision voltage source with an accuracy of 0.01% or better. The voltage source should be connected between J1-5 and J1-6. The serial cable should be connected between J2 and a serial port on your computer. See the transducer wiring diagram in the **POWERPOD-100** manual. Apply AC power to the **POWERPOD-100**. Verify that the **POWERPOD-100** lights up and that the instrument is displaying a stable reading. If no display appears after 1 or 2 seconds has elapsed, remove the ac power and check the fuse contained in the AC Power Connector at the rear of the **POWERPOD-100**.

If a stable display appears, allow 15-30 minutes for the **POWERPOD-100** to stabilize, then, perform one of the following calibration procedures.

5.2 Using a calibrated Flow meter/controller

1. The FS Cal (CAL) value must be entered prior to performing this calibration procedure. This may be accomplished using the keys on the front panel (see FS Cal (CAL) in the manual), or via the serial command [S][value][Cr][Lf].

2. Apply zero flow to the flow-meter/controller if calibration is done with a flow-meter/controller.

3. Insure that the flow-meter is properly warmed up and that it is zeroed (ie, The flow-meter should supply zero VDC to the **POWERPOD-100** between pins 5 and 6 of connector J1).

4. On your computer, start your serial communication software application (HyperTerminal by Hilgraeve and Tera Term Pro both work well) and insure that your computer and the **POWERPOD-100** are communicating.

5. Press the Zero button until the display flashes and indicates all 0000 (zeros) or send the **POWERPOD-100** the command, [Z][Cr][Lf] to re-zero the instrument.

6. Apply full scale flow to the flow-meter and insure that $5.000 \text{ VDC} \pm 0.005 \text{ VDC}$ is present between pins 5 and 6 of connector J1.

7. Send the **POWERPOD-100** the command, [F][Cr][Lf] and verify that the FS CAL annunciator is extinguished. The **POWERPOD-100** is now un-calibrated.

8. Again, send the **POWERPOD-100** the command, [F][Cr][Lf] and verify that the FS CAL annunciator is re-illuminated. The readout should display the FS Cal value within ± 1 digit.

7. The CALIBRATION sequence is now complete.

5.3 Using a Precision Power Supply

1. The FS Cal (CAL) value must be entered prior to performing this calibration procedure. This may be accomplished using the keys on the front panel (see FS Cal (CAL) in the **POWERPOD-100** manual), or via the serial command [S][value][Cr][Lf].

2. Short pins 5 & 6 on connector J1 with a small length of a good conductor.

3. On your computer, start your serial communication software application (HyperTerminal by Hilgraeve and Tera Term Pro both work well) and insure that your computer and the **POWERPOD-100** are communicating.

4. Press the Zero button until the display flashes and indicates all 0000 (zeros) or send the **POWERPOD-100** the command, [Z][Cr][Lf] to re-zero the instrument.

5. Remove the shorting conductor between pins 5 and 6 of J1.

6. Connect the precision power supply so that the negative or common lead is connected to J1-5 and the positive lead is connected to J1-6.

7. Press the mode button until the dP (decimal point) appears, then press the up arrow until the decimal point is in the desired position.

8. Press the zero button one time to return to normal display.

9. Adjust the precision voltage source to a value of 5.000 VDC , $\pm 0.005 \text{ VDC}$ across pins 5 & 6 as referenced on connector J1.

10. With $5.00 \text{ VDC} \pm 0.005 \text{ VDC}$ input to pins 5 & 6, send the **POWERPOD-100** the command, [F][Cr][Lf] and verify that the FS CAL annunciator is extinguished. The **POWERPOD-100** is now un-calibrated.

11. Again, send the **POWERPOD-100** the command, [F][Cr][Lf] and verify that the FS CAL annunciator is re-illuminated. The readout should display the FS Cal value within ± 1 digit.

NOTE: Calibration information (zero and scale factor values) are stored in non-volatile memory. They are updated every time calibration steps 6 through 8 above are performed. ZEROing the display changes and stores a new zero value but does not affect the scale factor value.

The **POWERPOD-100** may be rezeroed using the zero button on the front panel. ZEROing the **POWERPOD-100** without insuring that zero volts are present between pins 5 and 6 of J1 will result in erroneous readings.

**1. Switch Settings for RS232 and STPT Voltage Output
Must be depowered for changes to taken place.**

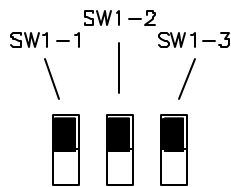

SWITCH POSITION	SW1-1 (PARITY)	SW1-2 (BAUD RATE)	SW1-3 (STPT 5V/10V)
UP	EVEN	2400	0-5V
DOWN	NONE	9600	0-10V

2. RS232 wiring to 25-pin and 9-pin Serial Port Connectors

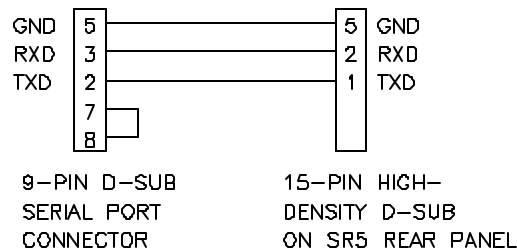
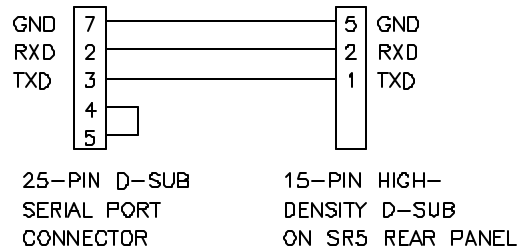

5.4 POWERPOD-100 RS232 Communication Protocol

COMMAND PROTOCOL	FUNCTION
[Z] [CR] [LF]	Zero the display, send Vofset value to StPt
[F] [CR] [LF]	Auto-calibrate Full Scale
[S] [value] [CR] [LF] 00001 to 99999)	Set CAL value (value range
[D] [value] [CR] [LF]	Set decimal point 1=X.XXXX 2=XX.XXX 3=XXX.XX 4=XXXX.X 5=XXXXX
[X] [value] [CR] [LF]	Set StPf value (value range 00000 to 99999)
[P1] [value] [CR] [LF]	Set value of SPH1 (value range +/-00000 to +/-99999)
[P2] [value] [CR] [LF]	Set value of SPL1 (value range +/-00000 to +/-99999)
[P3] [value] [CR] [LF]	Set value of SPH2 (value range +/-00000 to +/-99999)
[P4] [value] [CR] [LF]	Set value of SPL2 (value range +/-00000 to +/-99999)
[H1] [counts] [CR] [LF]	Set Low Hysteresis (counts = 00 to 99)
[H2] [counts] [CR] [LF]	Set Low Hysteresis (counts = 00 to 99)

REQUEST PROTOCOL	FUNCTION	RETURN MESSAGE
[R5] [CR] [LF]	R5 Display value	[P] [value] [CR] [LF]
[R8] [CR] [LF]	CAL value	[S] [counts] [CR] [LF]
[R9] [CR] [LF]	Decimal points	[D] [value] [CR] [LF] 1=X.XXXX 2=XX.XXX 3=XXX.XX 4=XXXX.X 5=XXXXX
[RX] [CR] [LF]	StPt value	[X] [value] [CR] [LF]
[R1] [CR] [LF]	SPH1 value	[P1] [value] [CR] [LF]
[R2] [CR] [LF]	SPL1 value	[P2] [value] [CR] [LF]
[R3] [CR] [LF]	SPH2 value	[P3] [value] [CR] [LF]
[R4] [CR] [LF]	SPL2 value	[P4] [value] [CR] [LF]
[R6] [CR] [LF]	Low Hysteresis counts	[H1] [counts] [CR] [LF]
[R7] [CR] [LF]	High Hysteresis counts	[H2] [counts] [CR] [LF]

6

Warranty

6.1 Warranty Repair Policy

Hastings Instruments warrants this product for a period of one year from the date of shipment to be free from defects in material and workmanship. This warranty does not apply to defects or failures resulting from unauthorized modification, misuse or mishandling of the product. This warranty does not apply to batteries or other expendable parts, nor to damage caused by leaking batteries or any similar occurrence. This warranty does not apply to any instrument which has had a tamper seal removed or broken.

This warranty is in lieu of all other warranties, expressed or implied, including any implied warranty as to fitness for a particular use. Hastings Instruments shall not be liable for any indirect or consequential damages.

Hastings Instruments, will, at its option, repair, replace or refund the selling price of the product if Hastings Instruments determines, in good faith, that it is defective in materials or workmanship during the warranty period. Defective instruments should be returned to Hastings Instruments, **shipment prepaid**, together with a written statement of the problem and a Return Material Authorization (RMA) number. Please consult the factory for your RMA number before returning any product for repair. Collect freight will not be accepted.

6.2 Non-Warranty Repair Policy

Any product returned for a non-warranty repair must be accompanied by a purchase order, RMA form and a written description of the problem with the instrument. If the repair cost is higher, you will be contacted for authorization before we proceed with any repairs. If you then choose not to have the product repaired, a minimum will be charged to cover the processing and inspection. Please consult the factory for your RMA number before returning any product repair.

TELEDYNE HASTINGS INSTRUMENTS
804 NEWCOMBE AVENUE
HAMPTON, VIRGINIA 23669 U.S.A.
ATTENTION: REPAIR DEPARTMENT

TELEPHONE	(757) 723-6531 1-800-950-2468
FAX	(757) 723-3925
E MAIL	mailto:hastings_instruments@teledyne.com
INTERNET ADDRESS	http://www.teledyne-hi.com

Repair Forms may be obtained from the "Information Request" section of the Hastings Instruments web site.