

# TELEDYNE HASTINGS




# INSTRUMENTS

INSTRUCTION MANUAL

## VH/CVH SERIES VACUUM GAUGES and CONTROLLERS



 **TELEDYNE INSTRUMENTS**  
*Hastings Instruments*  
A Teledyne Technologies Company

 **ISO 9001**  
KEMA CERT 10192.01  
 Accredited by the Dutch  
Council for Accreditation (RvA)  
 Accredited by the Registrar  
Accreditation Board (RAB)

# Manual Print History

The print history shown below lists the printing dates of all revisions and addenda created for this manual. The revision level letter increases alphabetically as the manual undergoes subsequent updates. Addenda, which are released between revisions, contain important change information that the user should incorporate immediately into the manual. Addenda are numbered sequentially. When a new revision is created, all addenda associated with the previous revision of the manual are incorporated into the new revision of the manual. Each new revision includes a revised copy of this print history page.

Revision A (Document Number 106-121999) .....	December 1999
Revision B (Document Number 106-082002) .....	August 2002
Revision C (Document Number 106-082005) .....	August 2005
Revision D (Document Number 106-012006) .....	January 2006

**Visit [www.teledyne-hi.com](http://www.teledyne-hi.com) for WEEE disposal guidance.**

# TABLE OF CONTENTS

<i>SECTION 1.0 GENERAL INFORMATION</i> .....	5
1.1 Feature .....	5
1.2 Specifications, VH Models .....	5
1.2 Specifications, CVH Models .....	6
1.4 Accessories .....	6
1.4.1 Drop-Out Trap, Type DO-1 .....	6
1.4.2 Valved Quick-Connect, Types OS-V & OS-VR .....	6
1.4.3 Dual Valve Quick-Connect, Type OS-V2 .....	6
1.4.4 Hastings Seal-Nut, Type OS-H .....	6
1.4.5 Hastings Quick Connects .....	7
1.5 Hastings Reference Tube .....	7
<i>SECTION 2.0 INSTALLATION AND OPERATION</i> .....	8
2.1 Receiving Inspection .....	8
2.2 Power Requirements .....	8
2.3 Gauge Tube Installation .....	8
2.4 Panel Mounting .....	8
2.5 Electrical Connection .....	9
2.6 Operation of CVH Controllers .....	9
2.7 Notes on Vacuum Measurement .....	9
2.7.1 Outgassing .....	9
2.7.2 Ingassing .....	10
2.7.3 Effects of Thermal Conductivity .....	10
2.7.4 Effect of System Conductance .....	10
<i>SECTION 3.0 THEORY OF OPERATION</i> .....	11
3.1 Meter Faces .....	12

<i>SECTION 4.0 MAINTENANCE</i> .....	13
4.1 Troubleshooting .....	13
4.1.1 Electrical Connections .....	13
4.1.2 Gauge Tubes .....	13
4.1.3 Defective Meters .....	13
4.2 Calibration .....	13
4.2.1 Calibration Procedure .....	13
4.2.2 Alternate Procedure .....	13
4.3 Hastings Reference Tube .....	14
4.4 AC Supply Voltage .....	14
 <i>SECTION 5.0 SERVICE INFORMATION</i> .....	 15
5.1 Warranty Repair Policy .....	15
5.2 Non-warranty Repair Policy .....	15
 <i>SECTION 6.0 WARRANTY AND REPAIR</i> .....	 17
6.1 Warranty Repair Policy .....	17
6.2 Non-Warranty Repair Policy .....	17
 <i>SECTION 7.0 DIAGRAMS AND DRAWINGS</i> .....	 19
Transducer Outline Dimensions .....	20
Characteristics of Hastings Vacuum Gauge Tubes .....	22
Nomograms (DV-23 Gauge Tube) .....	23
Nomogram (DV-24 Gauge Tube) .....	25
Wiring for CVH .....	26
Mounting Dimensions .....	27

## 1.0 GENERAL INFORMATION

---

The Hastings Model VH Vacuum Gauge and Model CVH Vacuum Controller are economical analog instruments combining modular, solid state construction and taut-band meters. Gauge tubes have excellent stability and ruggedness, and provide pressure measurements over the 0-5000 millitorr range for Models VH-3, CVH-3, and CVH-23; or over the 0-50 torr range for Models VH-4, CVH-4, and CVH-24. The instruments incorporate voltage regulation and operate on 115 VAC or 230 VAC, 50 or 60 cycle. All VH and CVH instruments are available with dual-scale meter faces which include a millibar scale (see meter faces, page 8).

Environmental tests show that the gauge tube is stable over a wide temperature range. The low operating temperature of the directly heated, patented, noble metal thermopile in the gauge tube contributes greatly to a long, stable life.

Use of the Hastings improved, directly heated thermopile principle provides a stable, reliable, fast-response vacuum gauge at a moderate cost that outperforms many instruments costing considerably more.

### 1.1 Features:

#### VH VACUUM GAUGES

- Economical
- Ready for Mounting
- Rapid Response
- Taut-band Meters
- Internal Voltage Regulation
- Interchangeable, matched gauge tubes
- Choice of 115 or 230 volts: field changeable
- Suitable for 50 or 60 cycle
- Plug-in extension cables

#### CVH VACUUM CONTROLLERS

- All features of VH Vacuum Gauges
- Choice of single or double set point
- Automatic contactless control and indication
- Fail-safe: loss of power = loss of vacuum
- Adjustable control pointer eliminates guesswork in setting control points
- Contacts -- SPDT 5 amps, 230 volts AC
- Fast control action without "dead zone"

## 1.2 Specifications, VH Models:

- Power ..... 115/230 VAC, 50/60 Hz
- Range, Model VH-4 ..... 0-50 torr or 0-10 mbar
- Range, Model VH-3 ..... 0-5000 millitorr or 0-5 mbar
- Gauge Tubes ..... Model DV-24 for VH-4, Model DV-23 for VH-3
- Tube Connections ..... DV-24: 1/8" NPT, KF-16, KF-25 DV-23: 1/8" NPT, VCR, KF-16, KF-25
- Cables ..... 6-ft. (approx) power cable and 8-ft. gauge tube cable attached  
Extension cables available
- Dimensions ..... 4.12" wide X 3.52" high. Depth required, 3.00"
- Gauge Tube Leak Test ..... 10<sup>-8</sup> sccs
- Maximum Pressure ..... DV-23 & DV-24 gauge tubes = 50 psig
- Maximum Temperature ..... DV-23 & DV-24 gauge tubes = 100°C
- Weight (approx) ..... 1.20 oz.

## 1.3 Specifications, CVH Models:

- Power ..... 115/230 VAC, 50/60 Hz
- Range, Models CVH-4 and CVH-24 ..... 0-50 torr or 0-10 mbar full scale
- Range, Models CVH-3 and CVH-23 ..... 0-5 torr or 0-5 mbar full scale
- Gauge Tubes ..... Model DV-24 for CVH-4 & CVH-24 Model DV-23 for CVH-3 & CVH-23
- Cables ..... 6-ft. (approx) power cable, 8-ft. gauge tube cable, and 1-ft. cable for each relay contact. Extensions available
- Dimensions ..... 5.00" wide X 4.25" high. Depth required, 7" Barrel diameter, 2.75"
- Contacts ..... Rated 5 amp @ 230 volts AC non-inductive
- Control Mode ..... Continuous reading, automatic reset
- Weight (approx) ..... 3 lb. net, complete

## 1.4 Accessories:

### 1.4.1 Drop-Out Trap, Type DO-2

The Model DO-2 is a particle drop-out trap which also provides an effective optical baffle. It has the equivalent of eight 90 degree bends, and protects the gauge tube from flying particles, evaporated metals, etc. The gauge tube threads into the trap, which installs into the existing gauge tube fitting. Simple "piggy-back" installation is used. Construction is of monel/nickel plated brass. The DO-2 may be cleaned with steam, solvent, an air hose, ultrasonics, etc. 1/8" NPT fittings are used; female for gauge tube, male to system.

### 1.4.2 Valved Quick Connect, Type OS-V & OS-VR

The OS-V & OS-VR provide a quick-connect O-ring seal fitting for the gauge tube with a toggle type shut-off valve. They permit removal and replacement of a gauge tube in many systems without "breaking" the entire system to atmospheric pressure. They also permit closing off the tube during the "dirty" portion of a cycle. The OS-V & OS-VR install in 1/8" NPT female thread. Type OS-VR is a right-angle pattern valve. Size: 1" x 3" x 3-1/2"; brass construction.

### 1.4.3 Dual Valved Quick Connect, Type OS-V2

The OS-V2 is similar to the OS-V & OS-VR, except it permits use of an additional tube in a second pressure range, or as a calibration check against a production tube. It features an unused spare ready for use. The OS-V2 installs in a 1/8" NPT female threaded fitting of an existing gauge tube. It is adjustable for angled or straight installation. Size: 7-1/2" x 1" x 3-3/4"; brass construction.

#### **1.4.4 Hastings Seal-Nut, Type OS-H**

The OS-H is a metal hex nut with a Teflon insert. It threads over a 1/8" NPT male NPT thread and jams against the fitting to provide a dry, non-shredding, reusable vacuum-tight seal. The OS-H eliminates the use of messy liquid sealant. It may be used to install gauge tubes, quick connects, drop-out traps and other 1/8"NPT male fittings in vacuum systems. The OS-H is supplied in packages of 10, 25, 50, and 100.

#### **1.4.5 Hastings Quick Connects**

Hastings Quick Connects offer an O-ring sealed fitting for Hastings and other model gauge tubes with 1/8" pipe stems (.405" OD tubing). They provide a clean, dry, leak-tight seal and permit quick, easy removal and replacement of gauge tubes without wrenches or messy sealants.

See Product Bulletin 352 for further information and warnings on Hastings Installation Accessories.

### ***1.5 Hastings Reference Tube:***

The Hastings Reference Tube is an evacuated, sealed vacuum gauge tube accurately calibrated to precisely simulate a gauge tube at a given operating pressure. It is electrically equivalent to the metal and Glass gauge tubes used with Hastings Instruments. It permits quick and easy recalibration of Hastings Vacuum Gauge Indicators by merely plugging the instrument into the reference and adjusting the calibration "current set" potentiometer until the instrument reads the pressure noted on the reference. Hastings Reference Tubes are available equivalent to each Hastings Gauge Tube.

## 2.0 INSTALLATION AND OPERATION

---

This section is designed to assist in getting a new vacuum gauge or controller into operation as quickly and easily as possible. Please read the following very thoroughly before attempting to install the instrument.

### 2.1 *Receiving Inspection:*

Carefully unpack the Hastings Vacuum Instrument and any accessories that arrive with it. Inspect it for any obvious signs of damage due to shipment. Immediately advise the carrier who delivered the shipment if any damage is suspected.

Compare each component shipped against the packing list. Ensure that all parts are present (i.e. vacuum gauge, gauge tube, extension cables etc.). Optional equipment or accessories will be listed separately on the packing list.

### 2.2 *Power Requirements:*

Model VH and CVH Vacuum Instruments can operate on either 50 or 60 Hz AC. Standard VH and CVH models are set up at the factory to operate on 115 VAC. Units designated with a prefix "E" in the model number (i.e. EVH-3) are set up to operate on 230 VAC. NOTE: The supply voltage for each unit can be changed in the field by changing a jumper on the PC board. See Section 4.4 if this becomes necessary. All VH and CVH instruments come equipped with a standard three-prong plug.

An "ON-OFF" switch can be installed in the following manner. Cut the power cable to the desired length, and discard the plug. Connect the black lead to a properly rated single-pole, single-throw switch; connect the white lead to common (neutral), and connect the green lead to ground.

### 2.3 *Gauge Tube Installation:*

The type DV-23 gauge tube has a nickel-plated tube body with a standard 1/8" NPT male pipe thread, or stainless steel body with a VCR, KF-16, or KF-25 connection. The octal base is color coded orange. The DV-24 has a white base. All tubes of the same type are matched and interchangeable.

When mounting the gauge tube in the vacuum system, the preferred orientation is a vertical position with the open end pointing down, to prevent accumulation of liquid and solid particles.

The gauge tube is installed in the vacuum system by screwing it into an opening having standard 1/8" NPT pipe threads. The connection should be made vacuum-tight around the threads by solder, Teflon tape or Hastings Seal Nuts.

The stem of the gauge tube has a smooth section above the threads for use with an O-ring coupling.

Hastings Quick Connect Couplings, available as accessories, offer a simple and rapid method of installing the gauge tube in the vacuum system. These couplings, machined from solid brass stock, are available for several types of system connections.

The VCR connections consist of a VCR female nut, 9/16-18 UNF female threads w/.75 hex, with Cajon® #SS-4-VCR-3 and #SS-4-VCR-1. The gasket is not provided. Follow Cajon® instructions for making connection of these gauge tubes to the vacuum system. The KF connections are made using a centering O-ring and clamp (neither O-ring nor clamp are provided).

### 2.4 *Panel Mounting:*

If the vacuum instrument is a panel mount version, see the Mounting Templates, Section 6.0, for the panel cutout dimensions. CAUTION: The meter has a taut-band type movement and is not sealed. To prevent damage to the meter, the indicator should not be mounted on a panel which is subjected to motor vibration or a dust-laden environment. The meter face may be cleaned with water-dampened tissue. **DO NOT USE SOLVENTS TO CLEAN THE METER FACE.**

## **2.5 Electrical Connection:**

After the gauge tube is installed in the system, and the meter is installed in the panel, the two are connected together by plugging the gauge tube cable into the tube base. If the standard connecting cable furnished with your instrument is inadequate for your application, gauge tube extension cables type VP-(length)-VS are available in lengths of 12, 25, 50, and 100 feet. *DO NOT USE HASTINGS EXTENSION CABLES OTHER THAN TYPE VP-VS SINCE THE PIN CONNECTIONS AND NUMBER OF WIRES DIFFER.* Gauges and controllers are factory calibrated to include extensions when cables are ordered with the instrument at time of purchase. If extensions are added later without recalibration, an error of approximately 4% will exist for each additional 25 feet of #18, 4-conductor cable.

After the gauge tube is plugged into the cable, apply the appropriate AC voltage. The Hastings Vacuum Gauge or Controller is now reading the vacuum in the system. If the gauge tube is not under vacuum, the needle on the indicator should move up to read "ATM" (atmospheric pressure). When the power is turned off, the needle should return to the center dot near full scale, indicating that the power supply and the gauge tube are operating properly.

## **2.6 Operation of CVH Controllers:**

To check control circuits, turn the power on and move the set pointer knob on the front of the meter until the pointer passes the needle. As the pointer passes the needle, listen for the relay to operate. This indicates that the control circuit is operating properly. For double set-point controllers, both set-points should be checked.

The Hastings Vacuum Controller features a contactless, optical meter-relay which provides control throughout the entire scale. Set the adjustable control arm by moving the set-pointer to the desired pressure on the meter. As the pressure increases and the indicating needle passes the set-point, the relay is de-activated. The meter continues to indicate pressure over the entire scale independent of relay operations. External connections to the relay controls are accomplished by means of a one-foot long 3-conductor cable attached to the rear of the meter housing. The cable has a 3-pin male connector for use by the customer.

The double-point controllers have two set-points. Either set-point can be adjusted over 100% of scale, but will not cross over the other set-point and reverse the "LOW" and "HIGH" set-point designations. A green pointer indicates the position of the "LOW" set-point and is controlled by the green part of the dual adjust knob on the front of the meter. A red pointer indicates the position of the "HIGH" set-point and is controlled by the red part of the dual-adjust knob. For double-point controllers, two cables ("LOW" and "HIGH") are attached to the rear of the meter housing.

## **2.7 Notes On Vacuum Measurements:**

### **2.7.1 Outgassing**

Hastings Gauge Tubes are made of materials that have been proven by years of usage to be relatively free from outgassing. However, all surfaces of glass and metal that are exposed to the vacuum system liberate gases and vapors that were previously adsorbed during exposure to the atmosphere. If the surfaces are contaminated with foreign matter, this outgassing may be much more persistent than if the surfaces are clean. The possibility of outgassing must be considered in checking the accuracy of Hastings Gauges or in checking for leaks. This is especially important when working with pressures of less than 10 microns of mercury. In this range of pressures, outgassing from surfaces in a newly evacuated system may flood the enclosure. Also, if the system is being pumped continuously, gauges spaced at different distances from the pump will register different pressures. For reliable comparison of different vacuum gauges, it is necessary then to insure that the vacuum system be free of any outgassing or other sources of apparent leaks. This can best be determined by closing the system off from the pumps and observing if there is any rise in pressure within the range of interest.

### **2.7.2 Ingassing**

Ingassing is an effect opposite to outgassing, and can also lead to erroneous readings. Ionization gauges exhibit a kind of pumping action that tends to clean up residual gases in certain ranges of pressure, and thereby lowers the pressure. Also, if a cold trap is in a closed system, the total pressure may change considerably while condensable vapors such as water, carbon dioxide and mercury are being condensed.

### **2.7.3 Effect of Thermal Conductivity**

All Hastings Vacuum Instruments are originally calibrated in dry air. Since this calibration is a function of thermal conductivity, any gas having a thermal conductivity different from that of air will also have a different calibration. Nomograms are provided on pages 26, 27, & 28 to correct indicated pressures to actual pressures for several of the common gases encountered in vacuum work.

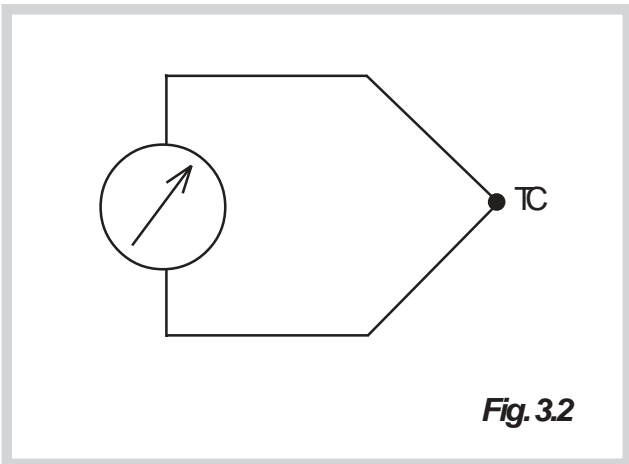
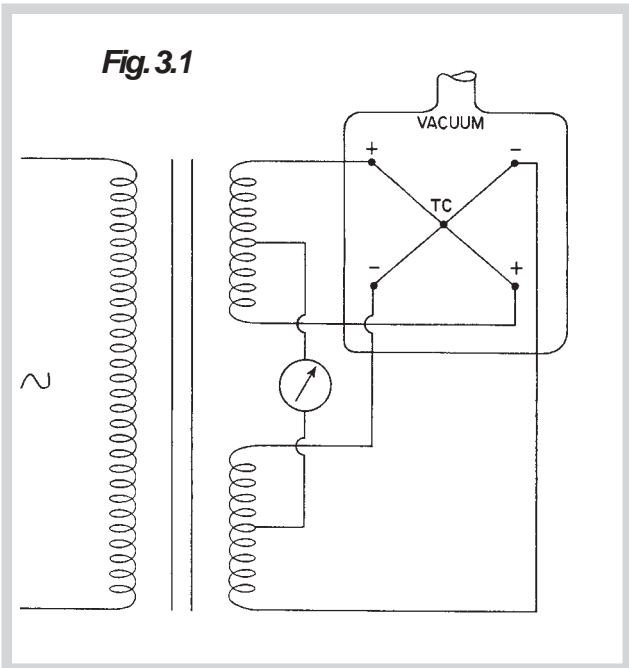
### **2.7.4 Effect of System Conductance**

Each element that makes up a vacuum system has associated with it a certain conductance (this is the opposite of resistance). For example, baffles, connecting tubing, and sharp turns can all cause pressure drops throughout the system during pumping and during the time the system is reaching static equilibrium. It is not an uncommon occurrence to measure different pressures at different locations in a vacuum system. In checking the calibration of any vacuum gauge, care must be taken to insure that the gauge and the reference are at the same pressure.

### 3.0 THEORY OF OPERATION

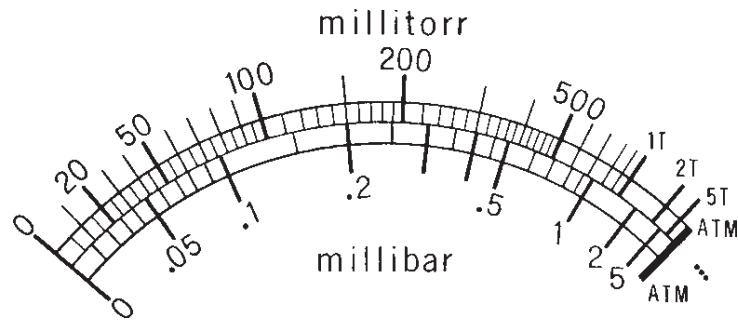
Two noble wires, welded in the center, form thermocouples (refer to Figure 3.1). The ends are welded to reference junctions and a constant alternating current from the dual secondaries of the transformer heats each wire independently to the same temperature rise above ambient. The d-c thermoelectric EMF generated by this temperature rise is dependent upon the applied power and the cooling effect (thermal conductivity) of the surrounding gas. As the pressure changes, the thermal conductivity changes, causing a change in generated EMF. Since the reference junctions are at ambient temperature and the temperature rise above ambient is the same at constant heating power and constant pressure, compensation for temperature is an inherent characteristic of the device.

If the secondaries of the transformer are balanced and the noble wires are welded in the midpoint, this results in a balanced bridge for AC voltage. The only voltage between the center taps of the transformers is the DC EMF generated by the thermocouple junction. The DC voltage is applied to a millivoltmeter which is scaled in units of pressure to directly read the absolute pressure in the tube. See Figure 3.2 and dual scale meter faces shown on the next page.

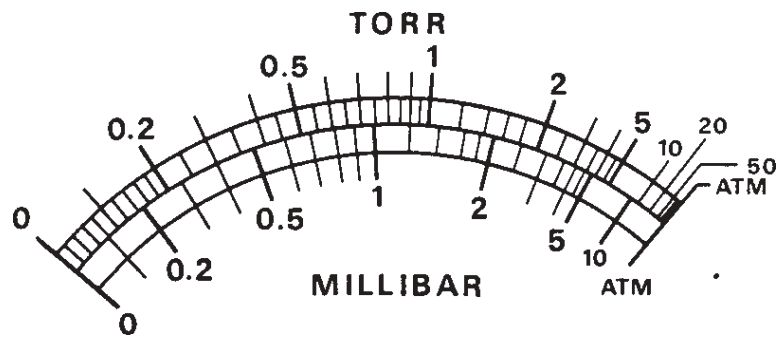


**Fig. 3.2**

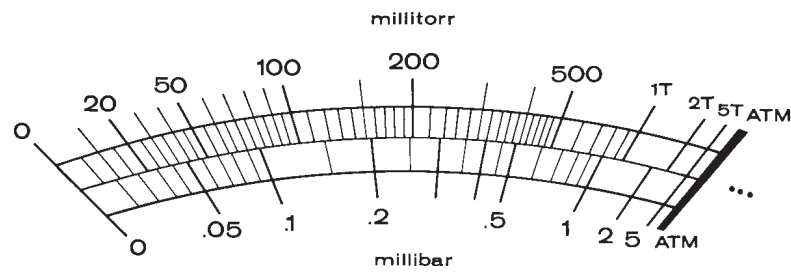
### 3.1 Meter Faces



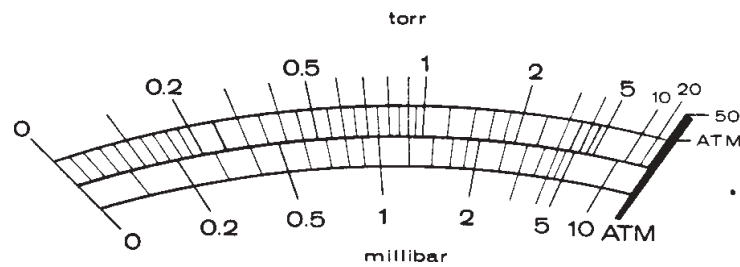
**Models VH-3 & EVH-3**  
**Uses Type DV-23 Gauge Tube**



**Models VH-4 & EVH-4**  
**Uses Type DV-24 Gauge Tube**



**Models CVH-3, CVH-23, ECVH-3 & ECVH-23**  
**Uses Type DV-23 Gauge Tube**



**Models CVH-4, CVH-24, ECVH-4 & ECVH-24**  
**Uses Type DV-24 Gauge Tube**

This section contains service and calibration information. Some portions of the instrument are delicate. Use extreme care when servicing the vacuum gauge or controller. The potentiometer positions and the electrical components referred to in the troubleshooting section can be found in Section 6.0 on the electrical component layout drawing.

### **4.1 Troubleshooting:**

If the gauge or controller fails to operate, the following procedure for troubleshooting will be helpful.

#### **4.1.1 Electrical Connections**

Check the plug, power source, and any switches to be sure that power is being applied to the circuit.

Check the gauge tube cable and socket connections at the gauge tube. The voltage between pins 2 and 4 or pins 6 and 8 should be approximately 0.2 volts AC.

If a circuit failure has occurred, return the instrument to the factory for repairs.

#### **4.1.2 Gauge Tubes**

The most common cause of failure is the gauge tube. The gauge tube can be checked quickly by substituting a new clean gauge tube in the system. The indication obtained with the new tube can then be compared with the indication obtained with the old tube.

The gauge tube can be checked for physical damage (broken couples, etc.) by removing the tube from the system and checking for continuity between pins 2 and 4 and pins 6 and 8. *DO NOT ATTEMPT TO CHECK FOR CONTINUITY WITH THE GAUGE TUBE EVACUATED OR DAMAGE TO THE TUBE MAY RESULT.* (Note that a Hastings Reference tube is always evacuated). If continuity (approximately 5 ohms) does not exist between the specified pins, replace the tube with a new gauge tube.

A contaminated gauge tube can be cleaned by carefully filling the tube with a solvent such as a CFC free cleaner. Rock the tube gently (do not shake) to loosen contamination. Rinse the tube with alcohol and bake at approximately 150°F to de-gas.

#### **4.1.3 Defective Meters**

If the meter is damaged, replacement meters are available from Hastings Instruments. Refer to the service information in Section 5.0 for the appropriate parts numbers.

### **4.2 Calibration:**

Hastings Vacuum Gauges and Vacuum Controllers are calibrated at the factory and seldom need adjustment. Calibration shifts are usually caused by damaged or contaminated gauge tubes, or gauge tube extensions not included in the factory calibration. Refer to the sections on "TROUBLESHOOTING" (above) and "ELECTRICAL CONNECTION" (page 5) before proceeding with recalibration.

#### **4.2.1 Calibration Procedure**

1. With the power off, adjust the small slotted mechanical zero screw on the front of the meter so the indicating needle is over the center dot (VH-4, CVH-4, and CVH-24 single dot) near full scale.
2. A reference pressure of less than one micron must be established to set the gauge for zero pressure. The exact pressure need not be known so long as it is below one micron. With the power on, pump the gauge tube for 15-30 minutes to eliminate any outgassing from the tube.
3. A trimpot is mounted inside the aluminum cover and is accessible through a small hole on the side of the cover. Adjust the trimpot until the indicator reads zero pressure.

#### **4.2.2 Alternate Procedure**

A reliable pressure standard, such as a capacitance manometer or a liquid nitrogen trapped McLeod type gauge, may be used if the system pressure is greater than one micron or if more than one calibration point is desired. To avoid outgassing, do not use an untrapped McLeod, a chemical-trapped McLeod, or Tygon tubing for calibration.

Adjust the calibration trimpot so the meter indicates the same pressure as the reference.

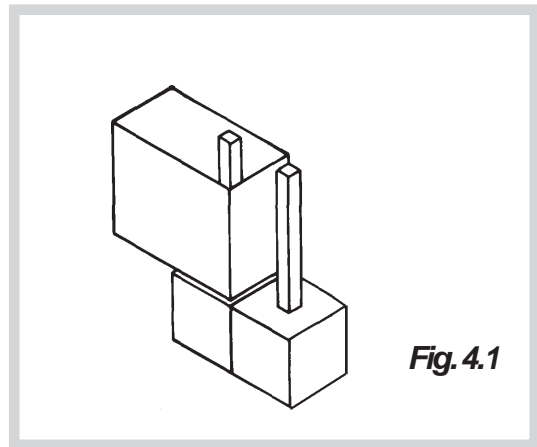
### 4.3 Hastings Reference Tube:

The Hastings Reference Tube, Type DB-33, is an evacuated, sealed tube which is accurately calibrated. The DB-33 Reference Tube connects to the gauge tube cable octal socket, and simulates a DV-23 Gauge Tube under the designated pressure. Adjust the calibration trimpot so the meter indicates the pressure marked on the reference tube. For models using the DV-24 Gauge Tube, use only a Hastings Type DB-44 Reference Tube.

### 4.4 AC Supply Voltage:

The standard vacuum instruments (VH and CVH models) are set up for operation on 115 VAC. The models with a leading "E" in the model number (EVH-3, EVH-4, ECVH-3, ECVH-23, ECVH-4, ECVH-24) are set up for operation on 230 VAC at the factory. If operation of a VH instrument on another supply voltage (different than the factory setting) is desired, the voltage can be changed in the field). This will require recalibration of the meter, however. Follow the procedure below to change the supply voltage. If operation of a CVH instrument on another supply voltage (different than the factory setting) is desired, you must consult your factory representative.

1. Remove all AC supply voltage from the unit.
2. Remove strain reliefs from gauge and power cables.
3. Remove two 1/4-28 screws from back of rear cover.
4. Pull rear cover off unit.
5. Locate jumper P1. If operation on 115 VAC supply is desired, install jumper over both pins of P1. If operation on 230 VAC supply is desired, install jumper over one pin as shown in Fig. 4.1.
6. Re-assemble unit.
7. Adjust mechanical zero on front of meter so the indicating needle is over the center dot (VH-4, single dot) near full scale.
8. Return AC power to the unit and allow it to warm up for a few minutes.
9. Recalibrate using calibration procedure, Sections 4.2.1 and 4.2.2; or use a reference tube as mentioned in Section 4.3.



## 5.0 SERVICE INFORMATION

---

The following is a list of the available replacement parts and their factory stock numbers:

<b>MODEL NO.</b>	<b>STOCK NO.</b>	<b>DESCRIPTION</b>
DV-23	55-73	Gauge Tube for all VH-3, CVH-3, & CVH-23 models
DV-24	55-89	Gauge Tube for all VH-4, CVH-4, & CVH-24 models
DB-33	55-106	Reference Tube for all VH-3, CVH-3, & CVH-23 models
DB-44	55-107	Reference Tube for all VH-4, CVH-4, & CVH-24 models
Meter	55-74	Meter for all VH-3, CVH-3, & CVH-23 models
Meter	55-88	Meter for all VH-4, CVH-4, & CVH-24 models

To place an order or obtain information concerning replacement parts, contact the factory or our local manufacturer's representative in your area. See below, or this manual's last page for the address or phone number. When ordering, include the following information:

- Instrument model number
- Part description
- Hastings part number



## 6.0 WARRANTY

---

### 6.1 Warranty Repair Policy

Hastings Instruments warrants this product for a period of one year from the date of shipment to be free from defects in material and workmanship. This warranty does not apply to defects or failures resulting from unauthorized modification, misuse or mishandling of the product. This warranty does not apply to batteries or other expendable parts, nor to damage caused by leaking batteries or any similar occurrence. This warranty does not apply to any instrument which has had a tamper seal removed or broken.

This warranty is in lieu of all other warranties, expressed or implied, including any implied warranty as to fitness for a particular use. Hastings Instruments shall not be liable for any indirect or consequential damages.

Hastings Instruments, will, at its option, repair, replace or refund the selling price of the product if Hastings Instruments determines, in good faith, that it is defective in materials or workmanship during the warranty period. Defective instruments should be returned to Hastings Instruments, **shipment prepaid**, together with a written statement of the problem and a Return Material Authorization (RMA) number. Please consult the factory for your RMA number before returning any product for repair. Collect freight will not be accepted.

### 6.2 Non-Warranty Repair Policy

Any product returned for a non-warranty repair must be accompanied by a purchase order, RMA form and a written description of the problem with the instrument. If the repair cost is higher, you will be contacted for authorization before we proceed with any repairs. If you then choose not to have the product repaired, a minimum will be charged to cover the processing and inspection. Please consult the factory for your RMA number before returning any product repair.

TELEDYNE HASTINGS INSTRUMENTS

804 NEWCOMBE AVENUE

HAMPTON, VIRGINIA 23669 U.S.A.

ATTENTION: REPAIR DEPARTMENT

TELEPHONE (757) 723-6531

1-800-950-2468

FAX (757) 723-3925

EMAIL [hastings\\_instruments@teledyne.com](mailto:hastings_instruments@teledyne.com)

INTERNET ADDRESS <http://www.hastings-inst.com>

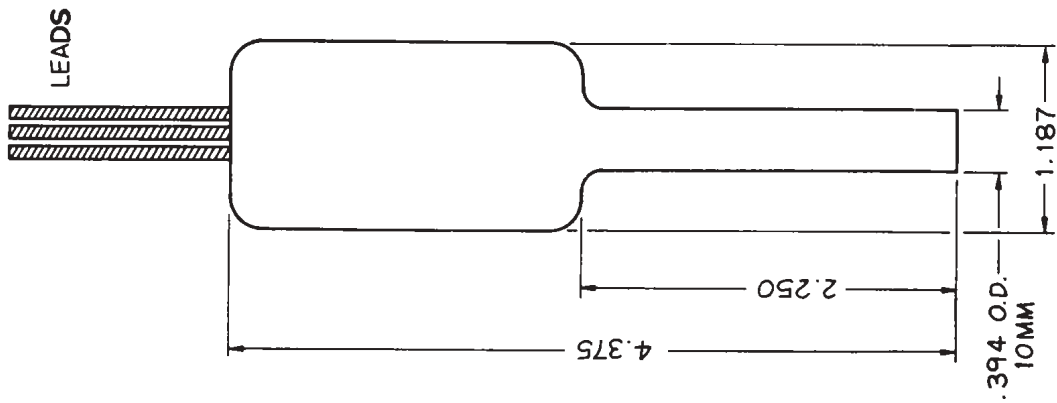
Repair Forms may be obtained from the "Information Request" section of the Hastings Instruments web site.



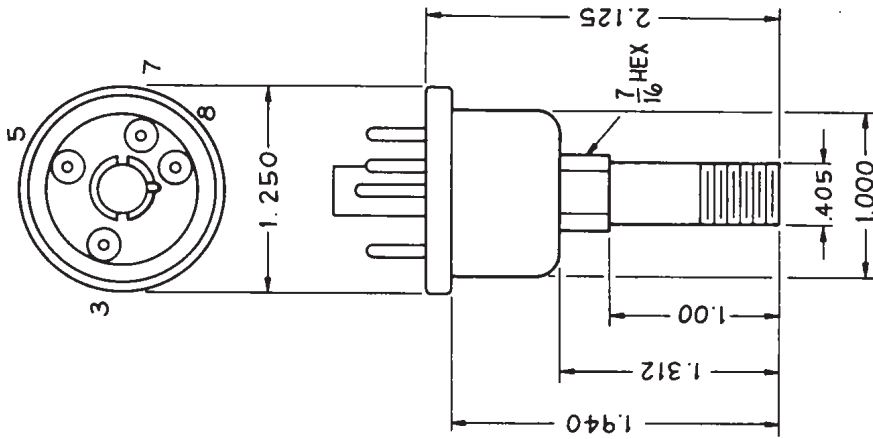
## 7.0 DRAWINGS AND DIAGRAMS

---

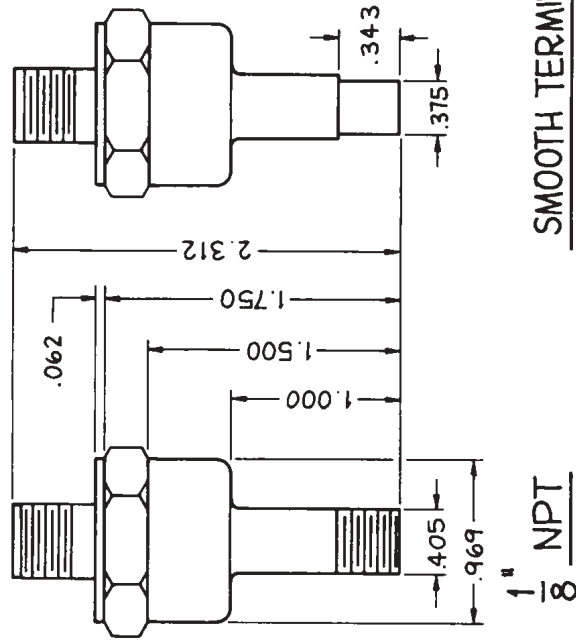
This sections contains the schematics, parts lists, overall assembly drawings, charts, and nomograms.



GLASSTUBE



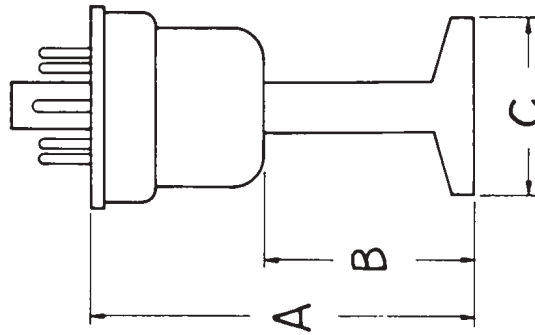
'R' SERIES TUBE



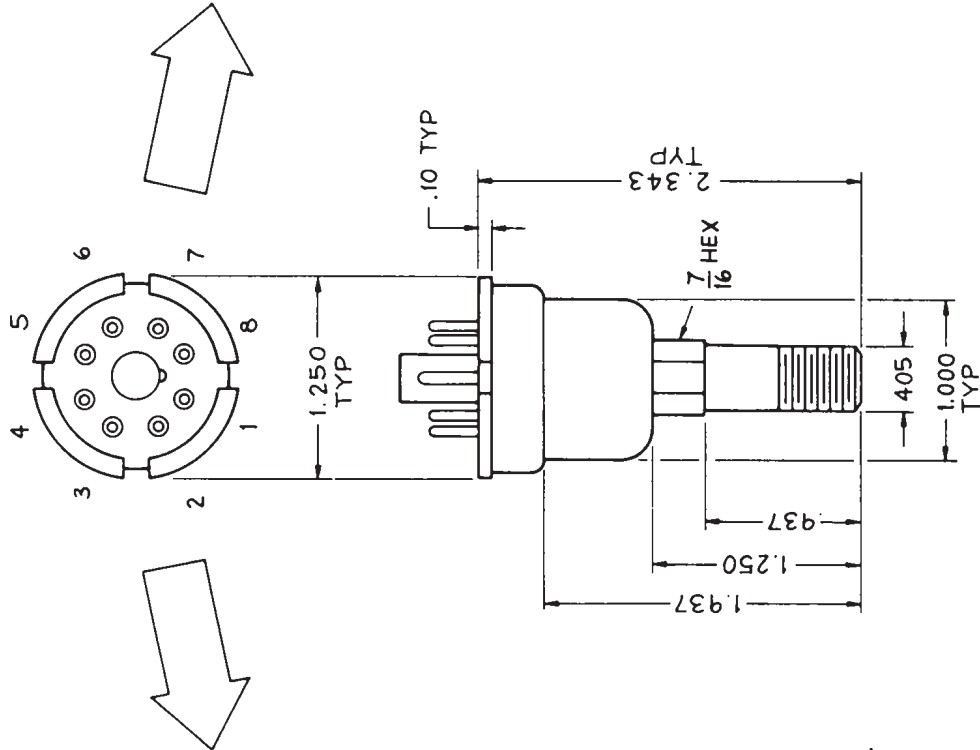
SMOOTH TERMINATION

STAINLESS / CERAMIC TUBE

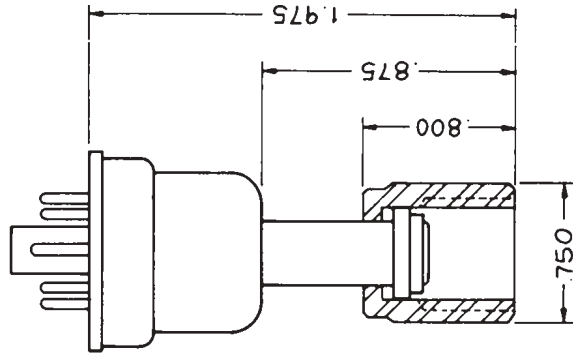
DIMENSION TABLE FOR KF-16/25			
MODEL TYPE	DIMENSIONS		
	A	B	C
KF-16	2.05	1.08	1.180
KF-25	2.15	1.15	1.57



**KF-16/25 CONNECTION**  
STAINLESS STEEL TUBE



**1/8 NPT CONNECTION**  
NICKEL PLATED STEEL TUBE



**VCR CONNECTION**  
STAINLESS STEEL TUBE

# CHARACTERISTICS OF HASTINGS VACUUM GAUGE TUBES

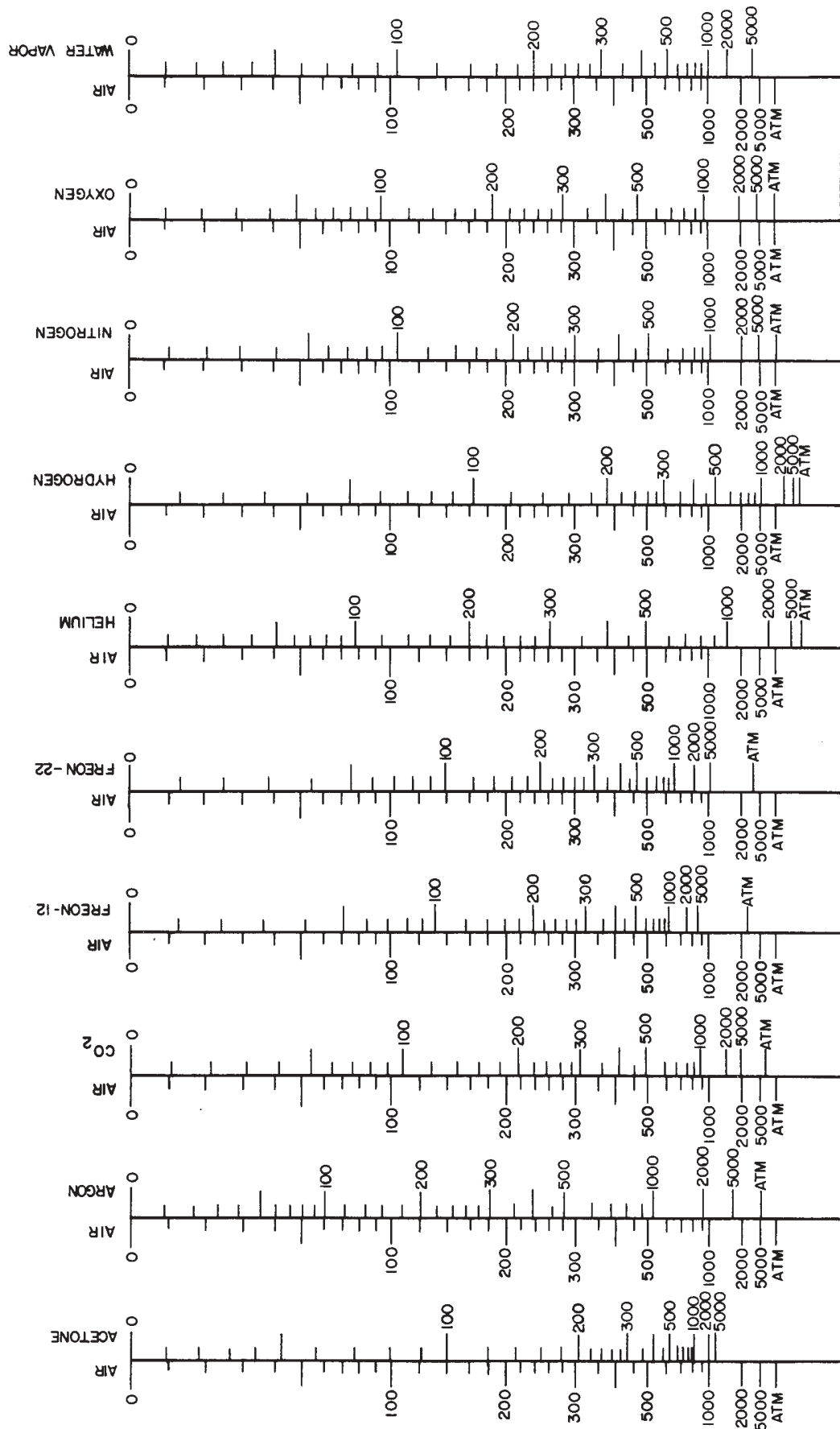
Metal Tube	DV-4D	DV-5M	DV-6M	DV-8	DV-23	DV-24	DV-760
"R" Series	DV-4R	---	DV-6R	---	---	---	---
Stainless/Ceramic	DV-34	---	DV-36	---	---	---	---
Pyrex	DV-16D	DV-18	DV-20	DV-31	DV-43	DV-44	---
Stnls. Steel w/VCR Connection	DV-4D-VCR	DV-5M-VCR	DV-6M-VCR	DV-8-VCR	DV-23-VCR	---	---
Stnls. Steel w/KF-16/25 Connection	DV-4D-KF-16/25	---	DV-6M-KF-16/25	---	DV-23-KF-16/25	DV-24-KF-16/25	---
Best Sensitivity Range	0.2 - 5 torr 0.1 - 5 mbar	2 - 20 mtorr 0.002 - .05 mbar	10 - 200 mtorr .01 - 2 mbar	0.1 - 10 mtorr ---	5 mtorr - 1 torr .01 - 2 mbar	.1 - 5 torr .1 - 5 mbar	1 - 800 torr 1 - 1100 mbar
Usable Range	0.1 - 20 torr 0.1 - 20 mbar	0.2 - 100 mtorr 0.001 - .1 mbar	1 - 1000 mtorr .01 - 1 mbar	0.1 - 10 mtorr ---	5 mtorr - 5 torr .01 - 5 mbar	.1 - 20 torr .1 - 10 mbar	1 - 800 torr 1 - 1100 mbar
Internal Volume of Gauge Tube	1/20 <sup>3</sup> 0.8cc	1/2 <sup>3</sup> 8.2cc	1/2 <sup>3</sup> 8.2cc	1/2 <sup>3</sup> 8.2cc	1/2 <sup>3</sup> 8.2cc	1/2 <sup>3</sup> 8.2cc	1/20 <sup>3</sup> 0.8cc
Thermopile Temperature In a High Vacuum At Atmosphere	250°C 30°C	48°C 1.5°C	300°C 6°C	120°C 10°C	400°C 10°C	400°C 35°C	N/A N/A
A-C Ampheres Through Tube	0.029	0.03	0.021	0.053	.04/.04	.03/.04	N/A
A-C Volts Across Tube	0.32	0.20	0.38	0.32	.20/.20	.19/.19	N/A
Watts Required by Tube	0.009	0.006	0.008	0.017	.016	.11	.018
Output at High Vacuum mv D-C	10	2	10	2	13	13	---
Internal Resistance - ohms	11	6	18	6	5/6	6.5/7.5	---
Response Time Zero to ATM - seconds	0.04	0.8	0.06	0.8	0.07	0.05	.002
ATM to Zero - seconds	0.16	25	2.9	25	3.0	.2	.002
A-C Connection Pin #	3-5	3-5	3-5	3-5	2-4, 6-8	2-4, 6-8	---
D-C Connection Pin #	7	7	7	7	---	---	---
Color of Base Metal Tube	Purple	Red	Yellow	Green	Orange	White	Lt. Blue

The above information includes nominal values only. Not to be used for design purposes or acceptance tests.

## PRESSURE AND TEMPERATURE DATA

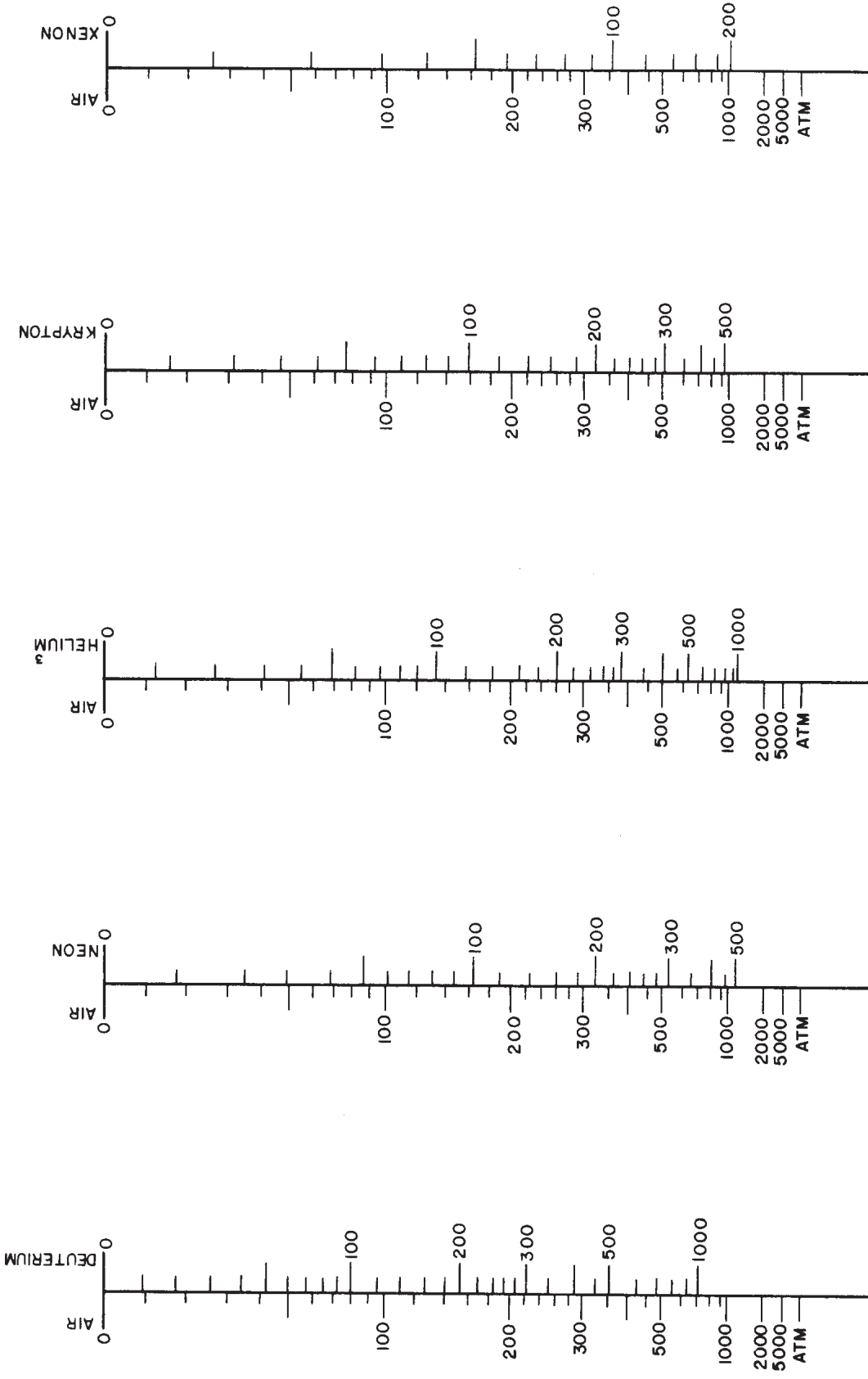
Tube Type	Max. Pressure	Max. Temperature
Metal: DV-4D, DV-4D-VCR, DV-4D-KF-16, & DV-4D-KF-25	150 psig	100°C
All other metal (except Model DV-760)	50 psig	100°C
"R" Series	250 psig	150°C
Stainless/Ceramic	600 psig	300°C
Pyrex	15 psig	400°C
Model DV-760	15 psig	40°C

The gauge tubes can be expected to withstand the listed pressure and temperature without rupture but they are not warranted as safe under these conditions. For critical conditions or special testing, contact factory.

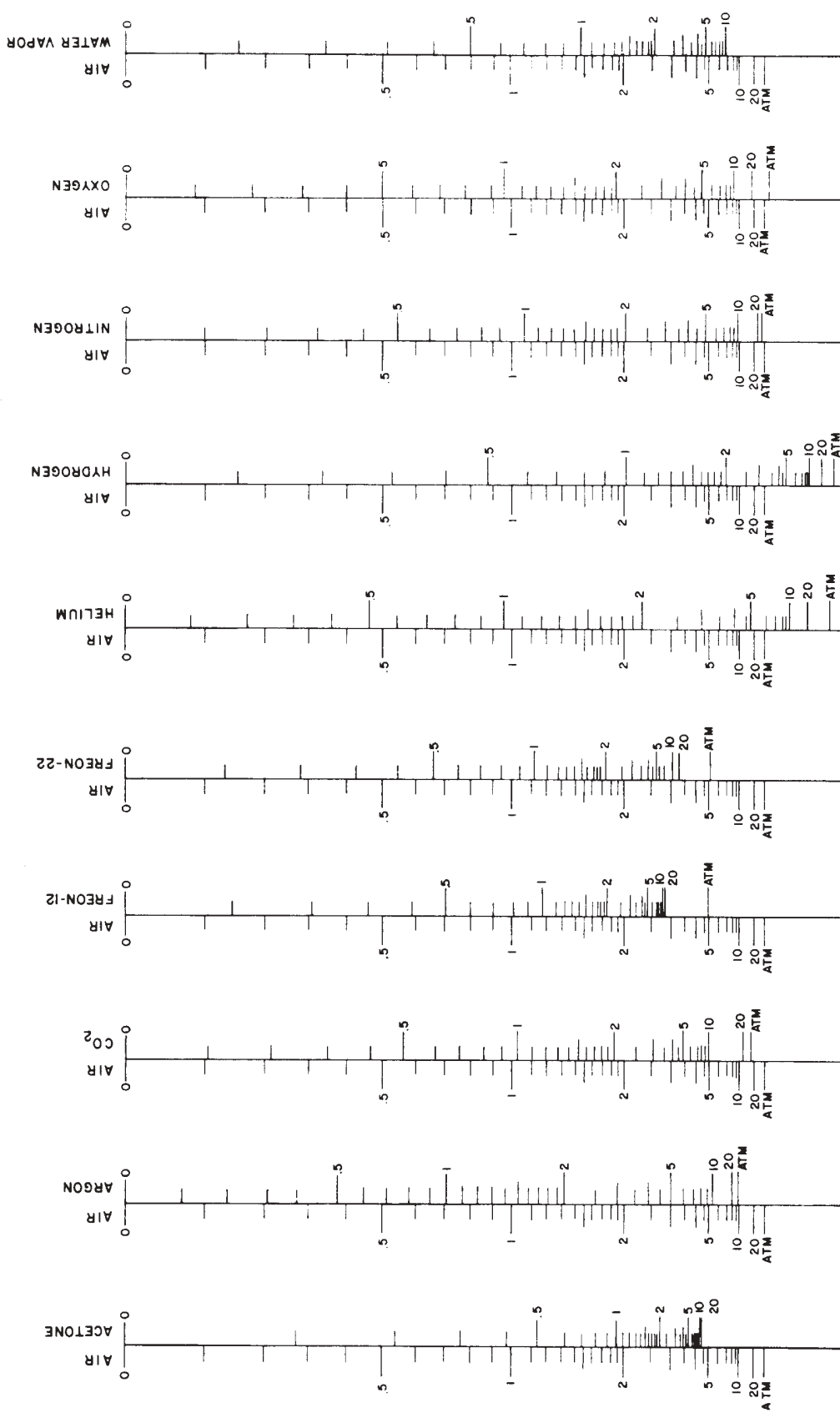


NOMOGRAM SHOWING CALIBRATION OF HASTINGS VACUUM GAUGES WHICH USE THE DV-23 GAUGE TUBE FOR GASES OTHER THAN AIR. TO FIND THE PRESSURE IN A GAS OTHER THAN AIR, LOCATE THE OBSERVED READING ON THE "AIR" SIDE OF THE APPROPRIATE SCALE AND READ, ON THE OPPOSITE SIDE OF THE SCALE, THE TRUE PRESSURE IN MICRONS OF MERCURY FOR THE GAS BEING MEASURED.

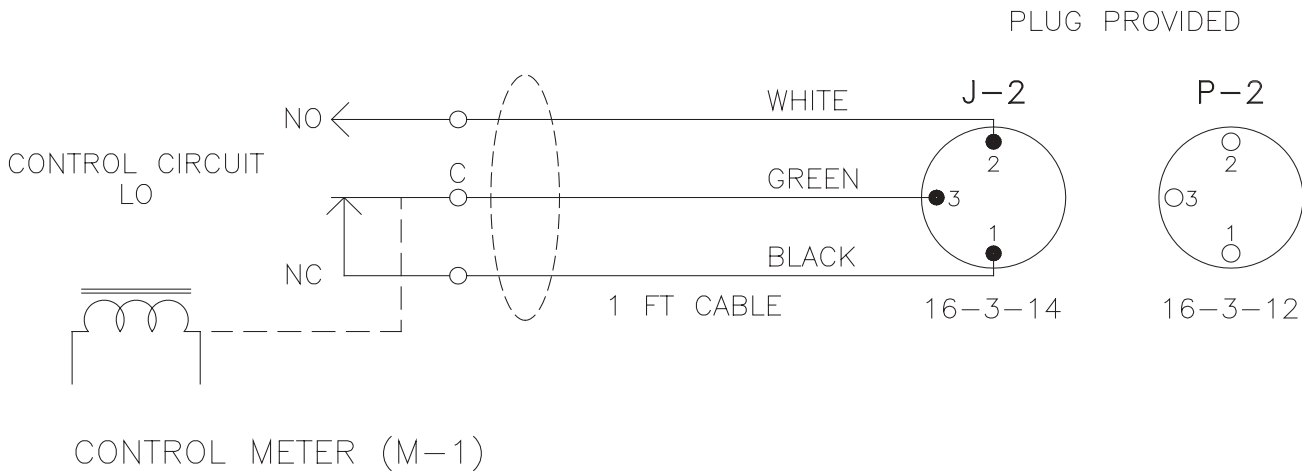
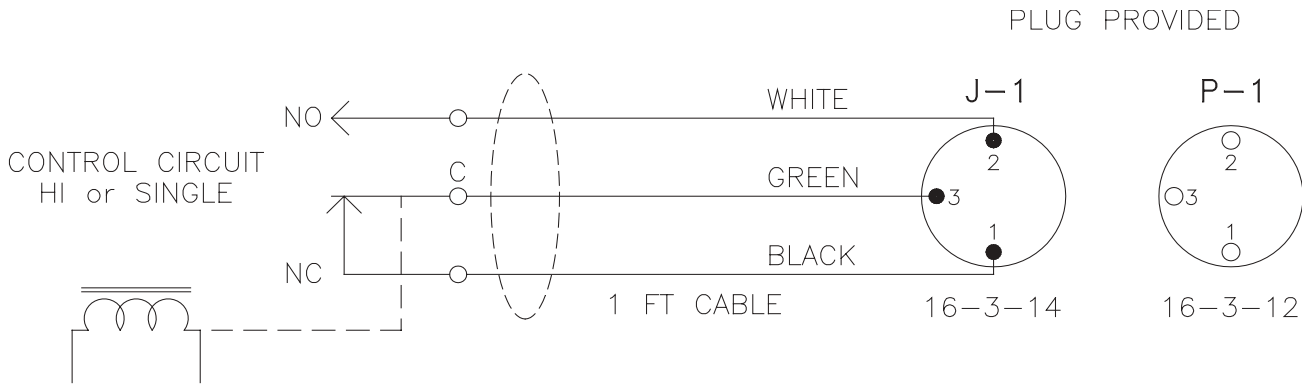
PRINTED IN U.S.A.  
 SEPTEMBER 1969



NOMOGRAM SHOWING CALIBRATION OF HASTINGS VACUUM GAUGES WHICH USE THE DV-23 GAUGE TUBE FOR GASES SHOWN ABOVE. TO FIND THE PRESSURE IN A GAS OTHER THAN AIR, LOCATE THE OBSERVED READING ON THE "AIR" SIDE OF THE APPROPRIATE SCALE AND READ, ON THE OPPOSITE SIDE OF THE SCALE, THE TRUE PRESSURE IN MICRONS OF MERCURY FOR THE GAS BEING MEASURED.



NOMOGRAM SHOWING CALIBRATION OF HASTINGS VACUUM GAUGES WHICH USE THE DV-24 GAUGE TUBE FOR GASES OTHER THAN AIR. TO FIND THE PRESSURE IN A GAS OTHER THAN AIR, LOCATE THE OBSERVED READING ON THE "AIR" SIDE OF THE APPROPRIATE SCALE AND READ, ON THE OPPOSITE SIDE OF THE SCALE, THE TRUE PRESSURE IN MILLIMETERS OF MERCURY FOR THE GAS BEING MEASURED.



**WIRING FOR CVH**

**Mounting Dimensions**

Shown are dimensional drawings for mounting Hastings VH, EVH, CVH, and ECVH Vacuum Instruments.

