

TELEDYNE HASTINGS INSTRUMENTS



INSTRUCTION MANUAL

AVG and AVC MODULE



Manual Print History

The print history shown below lists the printing dates of all revisions and addenda created for this manual. The revision level letter increases alphabetically as the manual undergoes subsequent updates. Addenda, which are released between revisions, contain important change information that the user should incorporate immediately into the manual. Addenda are numbered sequentially. When a new revision is created, all addenda associated with the previous revision of the manual are incorporated into the new revision of the manual. Each new revision includes a revised copy of this print history page.

Revision B (Document Number 137-0596).....	May 1996
Revision C (Document Number 137-082002)	August 2002
Revision D (Document Number 137-082005)	August 2005
Revision E (Document Number 137-042007).....	March 2007
Revision F (Document Number 137-062009).....	June 2009



Visit www.teledyne-hi.com for WEEE disposal guidance.

Hastings Instruments reserves the right to change or modify the design of its equipment without any obligation to provide notification of change or intent to change.

Table of Contents

1.0	GENERAL INFORMATION	4
1.1.	FEATURES	4
1.2.	VACUUM GAUGE TUBE	5
1.3.	ACCESSORIES	5
o	<i>Vacuum Gauge Tube</i>	5
o	<i>External Power Supply</i>	5
o	<i>External Control Relays [AVC module only]</i>	5
o	<i>Reference Tube Calibrator</i>	6
1.4.	SPECIFICATIONS	6
2.0	INSTALLATION.....	7
2.1.	VACUUM GAUGE TUBE, DV-4 OR DV-6	7
2.2.	AVG INTERFACE MODULE.....	8
o	<i>Input power</i>	8
o	<i>Output Signal</i>	8
o	<i>System Connection</i>	8
2.3.	AVC INTERFACE MODULE.....	8
o	<i>Input Power</i>	8
o	<i>Output Signal</i>	8
o	<i>External Control Relay</i>	8
o	<i>Set Point & Alarm Control</i>	8
o	<i>System Connection</i>	8
3.0	OPERATION	9
3.1.	PRESSURE MEASUREMENT	9
3.2.	PRESSURE CONTROL AND ALARM SET-UP - [AVC MODULE ONLY]	9
4.0	CALIBRATION	13
4.1.	REFERENCE TUBES	13
4.2.	VACUUM SYSTEM AND PRESSURE STANDARD.....	13
o	<i>DV-4 gauge tube</i>	13
o	<i>DV-6 gauge tube</i>	13
5.0	TROUBLESHOOTING.....	14
6.0	WARRANTY.....	ERROR! BOOKMARK NOT DEFINED.
6.1.	WARRANTY REPAIR POLICY	15
6.2.	NON-WARRANTY REPAIR POLICY.....	15

1.0 General Information

The AVG and AVC are compact electronic interface modules. They require the following, (1) Hastings DV-4 or DV-6 Gauge Tube, (2) external 10 - 30 VDC power source, and (3) display instrument which can use the nominal 0 - 1 VDC analog output signal. The system can measure and display pressures from 100 mTorr to 20 Torr using a DV-4 tube, or pressures from 1 mTorr to 1 Torr using a DV-6 tube. The AVG and AVC modules have the same pressure measurement capabilities; however, the AVC incorporates circuitry that provides adjustable set point control and alarm functions (figure 1-1).

1.1. Features

- Operates from external 10 - 30 VDC power supply or 120 VAC to 12 VDC power adapters.
- Output signal can be monitored using either analog or digital meter (1k ohm minimum input impedance).
- Output signal can be converted for computer monitoring and control applications.
- Lightweight and compact electronic interface module.
- Adjustable single set point control with alarm functions (AVC only).

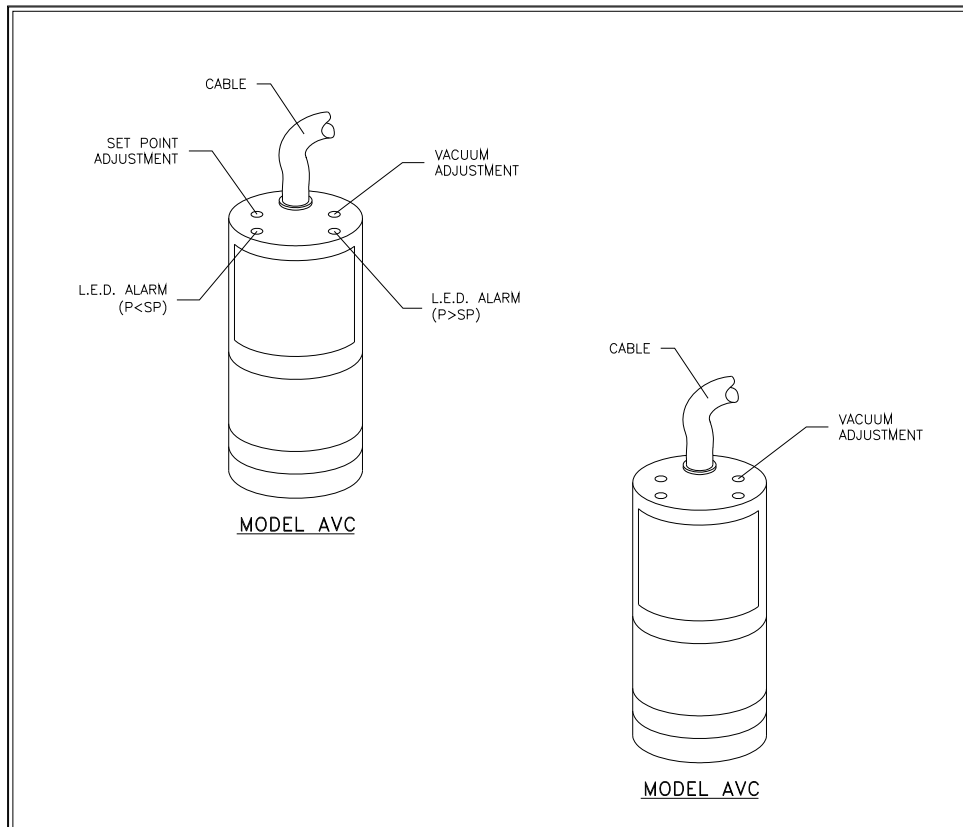

- Factory calibrated for use with Hastings DV-4 and DV-6 gauge tubes.
- Standard single point calibration, using Hastings DB-20 reference tube.
- Custom single point calibration in vacuum system, using external instrumentation.
-

1.2. Vacuum Gauge Tube

Operation of the Hastings gauge tube is based on a low voltage AC bridge which heats a noble metal thermopile. A change in pressure in the gauge tube changes the molecular collision rate and therefore the thermal conductivity of the gas or gas mixture surrounding the thermopile. This results in a temperature shift in the AC heated thermocouples A and B. The resultant temperature shift causes a change in the DC output from couples A and B inversely with pressure changes. The DC thermocouple C is in series with the circuit load. Thermocouple C provides compensation for transient changes in ambient temperature (figure 1-2).

1.3. ACCESSORIES

o Vacuum Gauge Tube

Hastings gauge tubes (vacuum sensors) are not included with the purchase of an AVG or AVC interface module. The DV-4 tube is required for measurements in the 100 mTorr - 20 Torr range, and the DV-6 tube is required for measurements in the 1 mTorr - 1 Torr range.

o External Power Supply

Any power supply capable of delivering 10 - 30 VDC at 50 mA (minimum) is recommended for use with the AVG and AVC interface modules.

o External Control Relays [AVC module only]

AVC interface modules can accommodate either one or two control relays. One relay circuit is energized when the pressure is above the set point, and the second relay circuit is energized when the pressure is below the set point. One adjustable set point is available for the two alarm circuits and indicators.

Requirements for the relays are as follows:

- Coil voltage must be the same as the power supply voltage for the AVC (12 to 24V) and the relay coil current should be 30 mA or less.
- External 10k ohm resistors can be used in place of relays for computer monitoring and control applications.

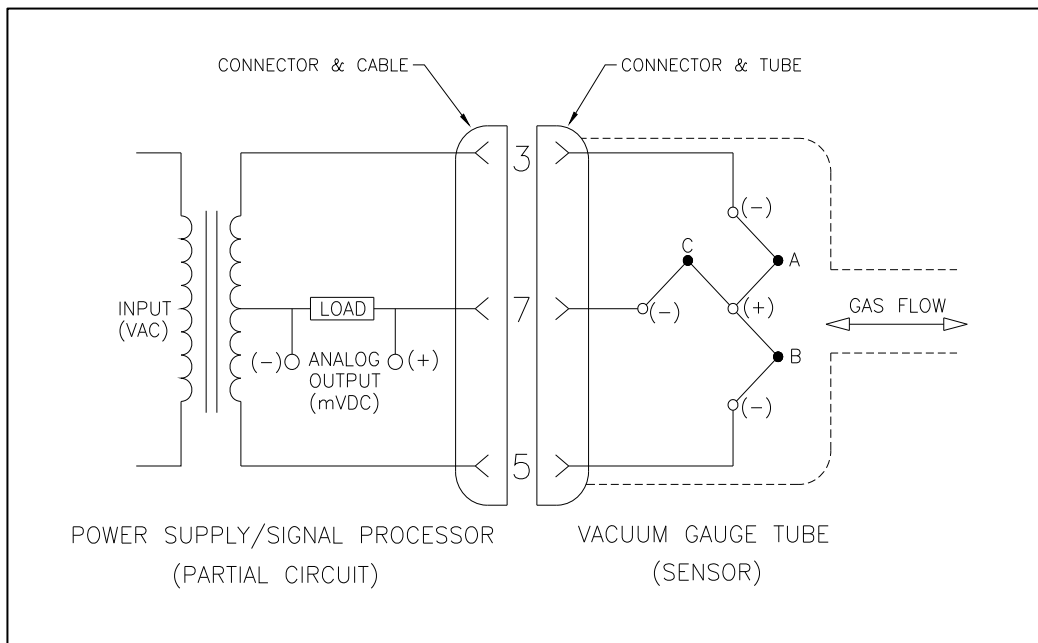

o **Reference Tube Calibrator**

Hastings DB-20 reference tube employs the same noble metal thermopile used in Hastings gauge tubes. The thermopile is sealed in a glass envelope that has been evacuated, baked, outgassed; it is then aged to ensure long-term stability. The sealed envelope is then housed in a protective metal shell to provide a rugged, trouble-free assembly.

The reference tube is calibrated to simulate a gauge tube at a specific operating pressure. It permits quick and easy AVG and AVC vacuum instrument calibration. Insert a reference tube into the octal connector-end of the VAG or VAC interface module, then adjust the "Pmin" potentiometer until the voltage noted on the reference tube decal is displayed on an external meter connected at the analog output terminations.

1.4. Specifications

Pressure range	100 mTorr to 20 Torr (with DV-4 gauge tube)
.....	1 mTorr to 1 Torr (with DV-6 gauge tube)
Analog signal output.....	nominal 0.060 to 1.2 VDC (with DV-4 gauge tube)
.....	Nominal 0.050 to 1.0 VDC (with DV-6 gauge tube)
Single set point range.....	nominal 0.0 to 1.1VDC (AVC module only)
Input power	1.5 watts max
Current drain	20 mADC @ 10-30 VDC (AVG/AVC with tube)
.....	50 mADC @ 12-24VDC (AVC with tube and relay)
Operating temperature	0-40°C ambient
Storage temperature	-10° to 50° C ambient
Dimensions length	3" (75mm)
.....	Diameter 1.3" (33mm)
Weight (approx)	3 oz (85 gm)

2.0 Installation

This section is presented to assist in placing the AVG and AVC into operation as quickly and easily as possible. Please read the following instructions thoroughly before installing and placing the instrument in-service.

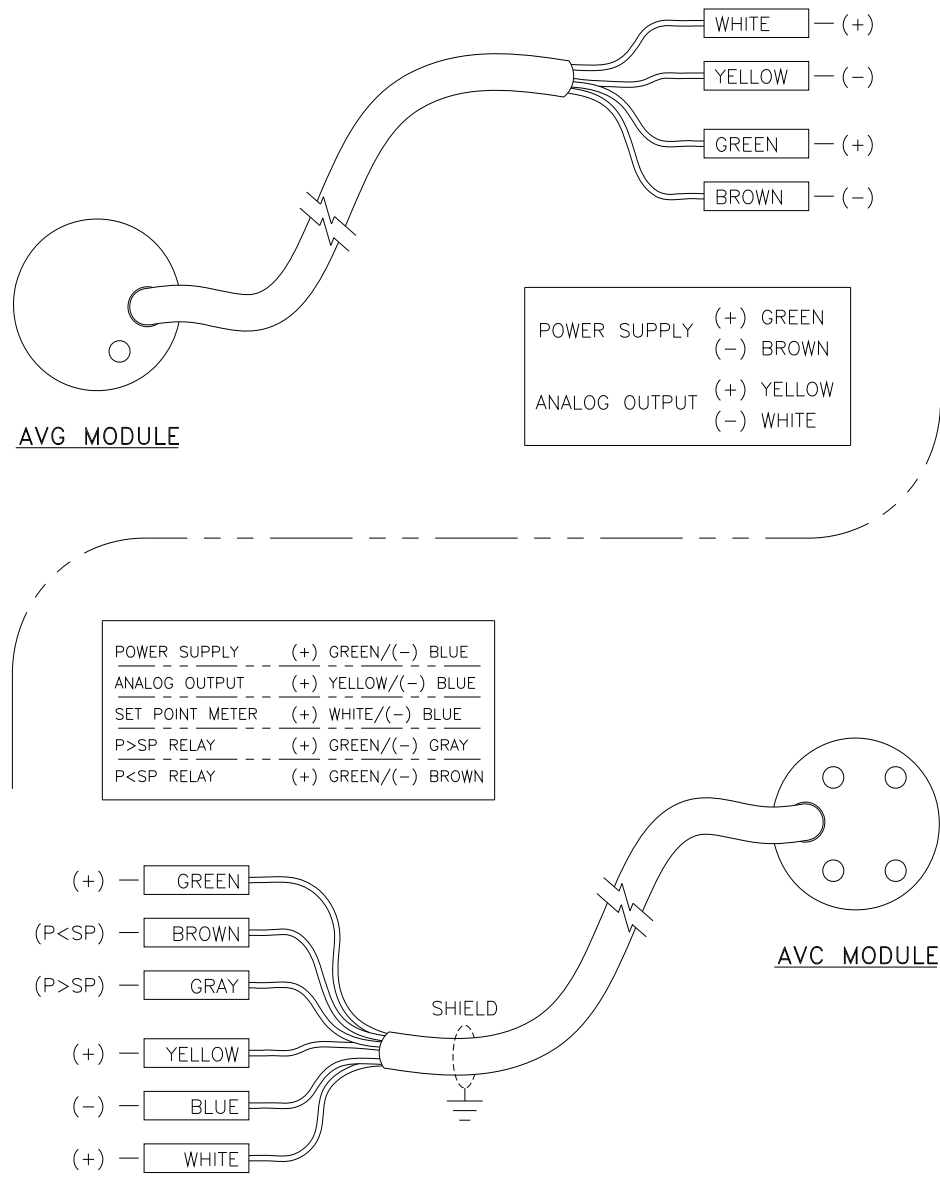

2.1. Vacuum Gauge Tube, DV-4 or DV-6

The vacuum gauge tube is shipped with a protective cap covering the evacuation port to keep the thermopile elements clean and free from physical damage. Remove the protective cap prior to tube installation.

The tube can be mounted in any orientation without affecting calibration or performance. The recommended position is with the tube vertical and stem-down. During tube installation apply appropriate sealant to minimize leakage. If using "Quick Connect" compression fittings, we recommend installing an isolation valve between vacuum system and fitting for ease of tube replacement.

2.2. AVG Interface Module

○ Input power

Connect the interface module brown wire (negative or input power LO) and green wire (positive or input power HI) to external power source 10 - 30 VDC. If using the 120 VAC to 12 VDC plug-in adapters, connect the module green wire (positive or input power HI) to adapter +12 VDC lead wire.

○ Output Signal

Connect the interface module white wire (negative or analog output LO) and yellow wire (positive or analog output HI) to external voltmeter, or computer interface having an input impedance of 1k ohm minimum, and a range of 0.0 - 1.2 VDC.

○ System Connection

Attach the interface module onto the octal base of the DV-4 or DV-6 gauge tube. When the gauge tube is installed stem-up, mechanically secure the module to the tube to prevent separation or disconnection while in-use.

2.3. AVC Interface Module

○ Input Power

Connect the interface module blue wire (negative or circuit LO) and green wire (positive or input power HI) to external power source 12 - 24 VDC. If using the 120 VAC 12 VDC plug-in adapter, connect the module green wire (positive or input power HI) to adapter +12 VDC lead wire.

○ Output Signal

Connect the interface module blue wire (negative or circuit LO) and yellow wire (positive or analog output HI) to external voltmeter, or computer interface having an input impedance of 1k ohm minimum, and a range of 0.0 - 1.2 VDC.

○ External Control Relay

WARNING

Improper wiring of relay to the AVC or incorrect relay may damage the AVC.

Relay (P>SP) is energized at pressure greater than set point pressure. Connect the interface module grey wire (negative or relay LO through open collector of transistor) to one side of relay and green wire (positive or input power HI) to free-end of relay coil. Relay coil current must not exceed 30 mADC at 12-24 VDC.

Relay (P<SP) is energized at pressure less than set point pressure. Connect the interface module brown wire (negative or relay LO through open collector of transistor) to one side of relay and green wire (positive or input power HI) to free-end of relay coil. Relay coil current must not exceed 30 mADC at 12-24 VDC.

If relay output is to be terminated by a computer interface unit, connect a 10k ohm resistor between module grey and green wires for (P > SP), brown and green wires for (P < SP). Control voltage is across the 10k ohm resistors. Current drain across resistor must not exceed 30 mA at 12 to 24 VDC.

○ Set Point & Alarm Control

Connect the interface module blue wire (negative or circuit LO) and white wire (positive or set point output HI) to a high impedance voltmeter. The set point adjustment range is from 0.0 - 1.1 VDC.

○ System Connection

Attach the interface module onto the octal base of the DV-4 or DV-6 gauge tube. When the gauge tube is installed stem-up, mechanically secure the module to the tube to prevent separation or disconnection while in-use.

3.0 Operation

This section is to familiarize the user with the AVG and AVC vacuum interface module. Section 3 also contains the appropriate look-up tables, pressure response curves and adjustment information for the control set point of the AVC interface module.

Before operating your system the AVG or AVC interface module and the appropriate gauge tube must be connected and installed as outlined in section 2 of this manual.

3.1. Pressure Measurement

Energize the AVG or AVC interface module and observe the analog output voltage displayed. Refer to the DV-4 or DV-6 pressure vs. voltage look-up data (tables 3-1 and 3-2) to determine the equivalent pressure.

3.2. Pressure Control and Alarm Set-up - [AVC module only]

Energize the AVC interface module and temporarily connect an external high impedance voltmeter across the interface module white and green wires. Refer to DV-4 or DV-6 pressure vs voltage look-up data (tables 3-1 and 3-2) to locate the set point pressure you desire. Adjust the Set Point control on the interface module until the equivalent voltage listed in the appropriate table is displayed.

ABS PRESSURE (Torr)	AVG/AVC OUTPUT (VDC)	ABS PRESSURE (Torr)	AVG/AVC OUTPUT (VDC)	ABS PRESSURE (Torr)	AVG/AVC OUTPUT (VDC)	ABS PRESSURE (Torr)	AVG/AVC OUTPUT (VDC)
---------------------	----------------------	---------------------	----------------------	---------------------	----------------------	---------------------	----------------------

1.0E-02	1.182	1.0E-01	1.107	1.0E+0	0.652	1.0E+01	0.216
2.0E-02	1.173	2.0E-01	1.028	2.0E+0	0.461	1.1E+01	0.211
3.0E-02	1.164	3.0E-01	0.950	3.0E+0	0.376	1.2E+01	0.206
4.0E-02	1.155	4.0E-01	0.890	4.0E+0	0.321	1.3E+01	0.201
5.0E-02	1.147	5.0E-01	0.843	5.0E+0	0.286	1.4E+01	0.196
6.0E-02	1.138	6.0E-01	0.797	6.0E+0	0.262	1.5E+01	0.191
7.0E-02	1.130	7.0E-01	0.755	7.0E+0	0.245	1.6E+01	0.189
8.0E-02	1.122	8.0E-01	0.719	8.0E+0	0.234	1.7E+01	0.187
9.0E-02	1.113	9.0E-01	0.685	9.0E+0	0.225	1.8E+01	0.184
						1.9E+01	0.182
						2.0E+01	0.179

Table 3.1: DV-4 Pressure – vs. Voltage Look-up Data

ABS PRESSURE (Torr)	AVG/AVC OUTPUT (VDC)	ABS PRESSURE (Torr)	AVG/AVC OUTPUT (VDC)	ABS PRESSURE (Torr)	AVG/AVC OUTPUT (VDC)	ABS PRESSURE (Torr)	AVG/AVC OUTPUT (VDC)
---------------------	----------------------	---------------------	----------------------	---------------------	----------------------	---------------------	----------------------

1.0E-03	1.004	1.0E-02	0.906	1.0E-01	0.374	1.0E+0	0.043
2.0E-03	0.993	2.0E-02	0.807	2.0E-01	0.204		
3.0E-03	0.982	3.0E-02	0.712	3.0E-01	0.142		
4.0E-03	0.97	4.0E-02	0.640	4.0E-01	0.107		
5.0E-03	0.959	5.0E-02	0.583	5.0E-01	0.083		
6.0E-03	0.948	6.0E-02	0.530	6.0E-01	0.067		
7.0E-03	0.937	7.0E-02	0.481	7.0E-01	0.059		
8.0E-03	0.927	8.0E-02	0.440	8.0E-01	0.054		
9.0E-03	0.916	9.0E-02	0.403	9.0E-01	0.048		

Table 3.2: DV-6 Pressure – vs. Voltage Look-up Data

(DV-4) Signal Vs. Pressure

AVC Output Curves.xls

$$f(x) = \frac{a + cx + ex^2}{1 + bx + dx^2}$$

a=1.1940044 b=1.2236541 c=0.48081293 d=0.43694915 e=0.063145813

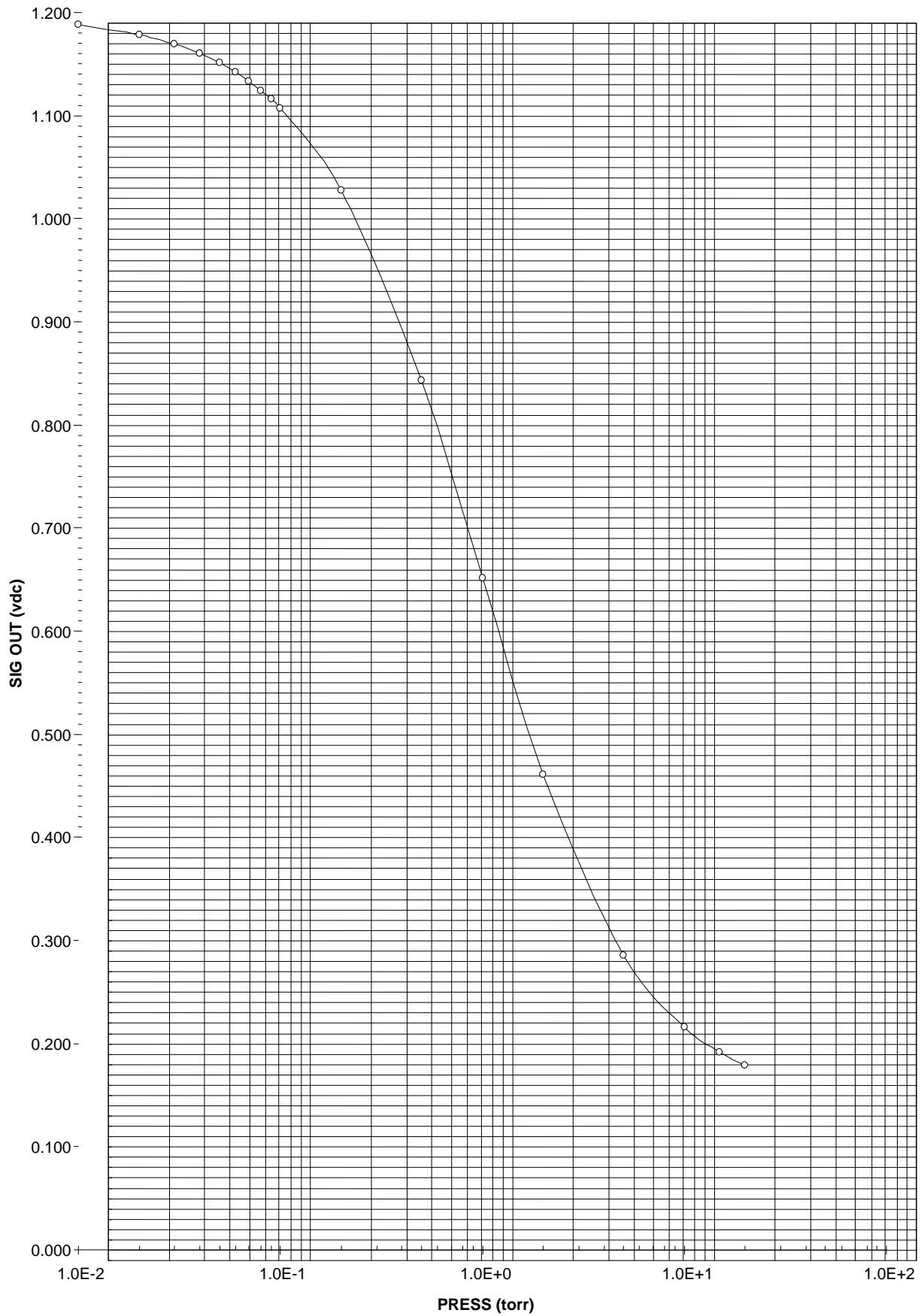

(DV-6) Signal Vs. Pressure
AVC Output Curves.xls
 $f(x)=(a+cx+ex^2)/(1+bx+dx^2)$
a=1.0169182 b=17.504809 c=5.9946085 d=158.10918 e=0.49789689

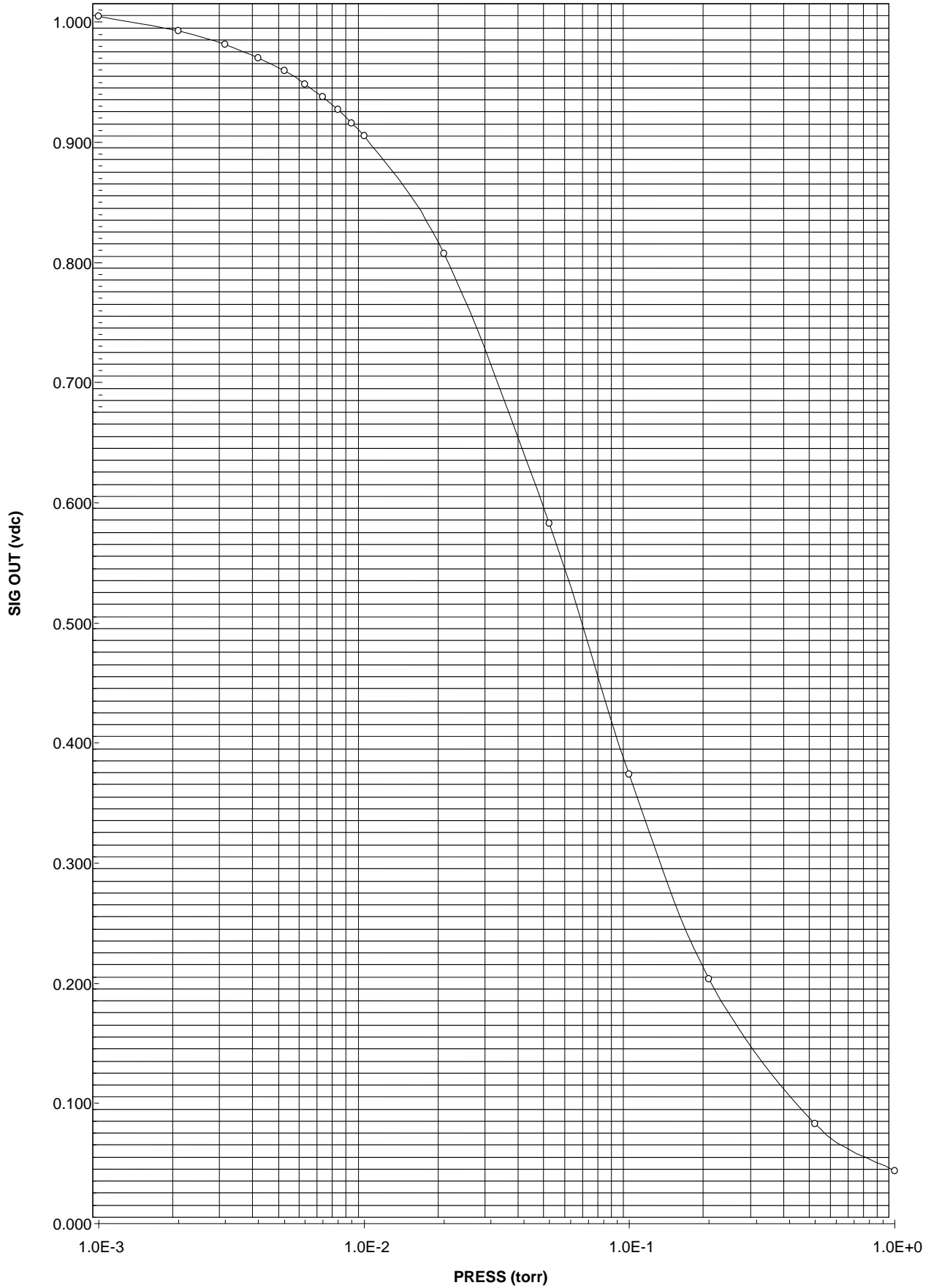

4.0 Calibration

Before calibrating your system the AVG or AVC interface module and the appropriate gauge tube must be connected and installed as outlined in section 2 of this manual.

4.1. Reference Tubes

Attach AVG or AVC interface module onto the octal base of the appropriate Hastings reference tube; For DV-4 use the DB-16D, for DV-6 use the DB-20. Energize the AVG or AVC vacuum interface module. Compare the voltage value equivalent to the calibration pressure on the reference tubes decal. Adjust the interface modules Vacuum control pot until the desired voltage is output by either the AVG or AVC.

4.2. Vacuum System and Pressure Standard

- **DV-4 gauge tube**

Attach the interface module onto the octal base of a DV-4 gauge tube and energize the AVG or AVC vacuum interface module. Evacuate the gauge tube to a pressure less than 0.001 Torr, then backfill using nitrogen gas or high purity air to a stable pressure of 0.100 Torr on the pressure standard. Using Table 3-1, determine the voltage value equivalent to calibration pressure of 0.100 Torr listed in the look-up data. Adjust the interface modules "Pmin" pot until the desired voltage is output by either the AVG or AVC.

- **DV-6 gauge tube**

Attach the interface module onto the octal base of a DV-6 gauge tube and energize the AVG or AVC vacuum interface module. Evacuate the gauge tube to a pressure less than 0.0001 Torr, then backfill using nitrogen gas or high purity air to a stable pressure of 0.001 Torr. Using Table 3-2, determine the voltage value equivalent to calibration pressure of 0.001 Torr listed in the look-up data. Adjust interface modules "Pmin" pot until the desired voltage is output by either the AVG or AVC.

6.0 Warranty

Symptom: Loss of output to display.

- Action:**
1. Possible input power supply failure. Check the module input voltage, repair or replace the power supply.
 2. Possible loss of the analog output signal from the module. Check the module signal output voltage and wire connections. Connect a DB-20 reference tube to the interface module. If signal is present and correct, replace the gauge tube. Troubleshoot or replace the analog display device.
 3. Consult the factory.

Symptom: Set point L.E.D. indicates but the control function is inoperative at the desired pressure.

- Action:**
1. Set point voltage value may be incorrect. Refer to the look-up tables (3-1 and 3-2) for the tube in use and adjust the set point voltage value.
 2. Use of the wrong type of vacuum tube with the interface module. Verify that the module is connected to either a DV-4 or a DV-6 type gauge tube. If not reconnect the module to one of the afore mentioned tubes dependent upon the desired range of measurement.
 3. Consult the factory.

Symptom: One or both of the external relays do not operate.

- Action:**
1. Relays may be defective. Check for correct supply voltage across the relay coils. Disconnect the relays grey and brown wires and check the coil continuity. Replace defective relay(s).
 2. Consult the factory.

Symptom: Either the (P>SP) or (P<SP) L.E.D. is inoperative.

- Action:**
1. L.E.D. or interface module circuitry is defective. Consult the factory and return the module for repair or replacement.

6.1. Warranty Repair Policy

Hastings Instruments warrants this product for a period of one year from the date of shipment to be free from defects in material and workmanship. This warranty does not apply to defects or failures resulting from unauthorized modification, misuse or mishandling of the product. This warranty does not apply to batteries or other expendable parts, nor to damage caused by leaking batteries or any similar occurrence. This warranty does not apply to any instrument which has had a tamper seal removed or broken.

This warranty is in lieu of all other warranties, expressed or implied, including any implied warranty as to fitness for a particular use. Hastings Instruments shall not be liable for any indirect or consequential damages.

Hastings Instruments, will, at its option, repair, replace or refund the selling price of the product if Hastings Instruments determines, in good faith, that it is defective in materials or workmanship during the warranty period. Defective instruments should be returned to Hastings Instruments, **shipment prepaid**, together with a written statement of the problem and a Return Material Authorization (RMA) number. Please consult the factory for your RMA number before returning any product for repair. Collect freight will not be accepted.

6.2. Non-Warranty Repair Policy

Any product returned for a non-warranty repair must be accompanied by a purchase order, RMA form and a written description of the problem with the instrument. If the repair cost is higher, you will be contacted for authorization before we proceed with any repairs. If you then choose not to have the product repaired, a minimum will be charged to cover the processing and inspection. Please consult the factory for your RMA number before returning any product repair.

TELEDYNE HASTINGS INSTRUMENTS

804 NEWCOMBE AVENUE

HAMPTON, VIRGINIA 23669 U.S.A.

ATTENTION: REPAIR DEPARTMENT

TELEPHONE (757) 723-6531
1-800-950-2468

FAX (757) 723-3925

E MAIL mailto:hastings_instruments@teledyne.com

INTERNET ADDRESS <http://www.hastings-inst.com>

Repair Forms may be obtained from the "Information Request" section of the Hastings Instruments