

# TELEDYNE HASTINGS INSTRUMENTS



## INSTRUCTION MANUAL

DIGITAL AVC  
(DAVC-4, DAVC-5, DAVC-6)



# Manual Print History

The print history shown below lists the printing dates of all revisions and addenda created for this manual. The revision level letter increases alphabetically as the manual undergoes subsequent updates. Addenda, which are released between revisions, contain important change information that the user should incorporate immediately into the manual. Addenda are numbered sequentially. When a new revision is created, all addenda associated with the previous revision of the manual are incorporated into the new revision of the manual. Each new revision includes a revised copy of this print history page.

Revision A (Document Number 174-062009).....	June 2009
Revision B (Document Number 174-072009).....	July 2009
Revision C (Document Number 174-072009) .....	July 2009
Revision D (Document Number 174-062010) .....	June 2010
Revision E (Document Number 174-082010).....	August 2010



**Visit [www.teledyne-hi.com](http://www.teledyne-hi.com) for WEEE disposal guidance.**

---

Hastings Instruments reserves the right to change or modify the design of its equipment without any obligation to provide notification of change or intent to change.

---

# Table of Contents

<b>1.0</b>	<b>GENERAL INFORMATION .....</b>	<b>4</b>
1.1	FEATURES .....	4
1.2	SPECIFICATIONS .....	4
1.3	COMPLIANCE DATA .....	5
1.4	SAFETY .....	5
	ACCESSORIES .....	5
<b>2.0</b>	<b>INSTALLATION.....</b>	<b>7</b>
2.1	POWER-I/O CABLE.....	7
2.2	POWER REQUIREMENTS & PIN OUT.....	7
2.3	SERIAL COMMUNICATIONS PIN OUT .....	7
2.4	ANALOG OUTPUT PIN OUT.....	7
2.5	PRESSURE ALARMS PIN OUT .....	7
<b>3.0</b>	<b>VACUUM GAUGE OPERATION.....</b>	<b>9</b>
3.1	QUICK START .....	9
3.2	ANALOG PRESSURE MEASUREMENT .....	9
3.3	ALARM SET POINT .....	12
3.4	DIGITAL COMMUNICATIONS. ....	12
3.5	OPERATION AND PERFORMANCE .....	14
3.6	GAUGE TUBE OPERATING PRINCIPLE.....	15
3.7	CALIBRATION PROCEDURE .....	15
<b>4.0</b>	<b>WARRANTY.....</b>	<b>17</b>
4.1	WARRANTY REPAIR POLICY .....	17
4.2	NON-WARRANTY REPAIR POLICY.....	17

# 1.0 General Information

This manual contains technical and general information relating to the installation, operation, and calibration of vacuum gauges and gauge tubes manufactured by Teledyne Hastings Instruments (THI).

For best performance, THI vacuum gauges should be operated with the appropriate THI gauge tube. Attempting to use a THI vacuum gauge with another manufacturer's tubes may result in damage to both the gauge and tube.

## 1.1 Features

The THI Digital AVC (DAVC), is a digital readout version of THI's AVC vacuum gauge. The heated gauge tube supplies an analog signal that is amplified for a zero to one volt signal out put. A precision A/D converter, in conjunction with a microprocessor, measures the gauge tube's signal output, converts the measurement to a pressure reading using the gauge tube's well defined output/pressure function, and then provides the result to the end user through a serial communications port.

The DAVC is available for use with two of THI's most popular gauge tube families: The DV-6 and DV-4. The DV-6 range is 1.0 - 1000 mTorr. The DV-4 range is 0.2 - 20 Torr. All gauge-tubes used with the Digital AVC feature long life and minimal maintenance due to the use of rugged, noble-metal, thermocouple (TC) gauge tubes that are designed specifically for each range.

## 1.2 Specifications

Input Power .....	12 – 30 VDC
.....	0.7 Watts
Cable.....	Combination power and RS232 cable, 1.5 meters, included
.....	For CE Compliance, cable should never exceed 3.0 meters
Weight (Approx.) .....	22 Oz's (624 Grams) W/O Tube & Cable
Height (Length) .....	2.6", W/O Tube & Cable
Width / Depth .....	1.75"
Operating temperature Range .....	-20°C to 70°C
Standard Metal Gauge Tube.....	(DV-6R, DV-5M, DV-4R):
Overpressure (Gauge tubes) .....	50 psig max.
Material of Construction .....	DAVC Housing: Aluminum
.....	Thermocouple: Glass, Noble Metal
Connections .....	High Density, 15-Pin, D Connector
.....	Octal Tube Socket for Thermocouple
Alarms .....	0.50 Amps, max.
Tube Leak Test .....	<1x10 <sup>-8</sup> atm cc/sec He

See tube Product Bulletin for available tube connection configurations.

## 1.3 Compliance data

CE Standard Compliance	
Test	Standard
SAFETY	EN61010
EMC/EMI Family	EN61326
CONDUCTED/RADIATED	EN55011
ESD	EN61000-4-2
RF	EN61000-4-3
CONDUCTED IMMUNITY	EN61000-4-6

## 1.4 Safety

The following symbols and terms may be found on THI products and/or in THI manuals and indicate important information.



When found on the device, this symbol indicates that the operator should refer to the manual for important instructions on the proper use of this device. When found in a manual, this symbol indicates that the reader should understand the implications contained in the text before operating the device.

The WARNING label indicates important information that should be heeded for safe and proper performance of the device.

The label, CAUTION, is used to indicate that damage to the power supply or equipment connected to it, could occur if directions are not followed. Warranty could be invalidated if the instructions in this manual are not followed.

## Accessories

### 1.4.1 Installation Accessories

THI offers a complete line of system attachments that permit easy maintenance for contaminated operations. Gauge tubes are offered with various system fittings to match almost any system requirement. Additionally, THI's complete line of quick disconnect attachments allows customers to install these special fittings and easily replace sensors without vacuum sealant or Teflon® tape. For particularly dirty systems, Hastings offers a particle dropout trap containing a series of nine separate baffles which prevent solid contaminants from having a direct path to the sensor's thermopile.

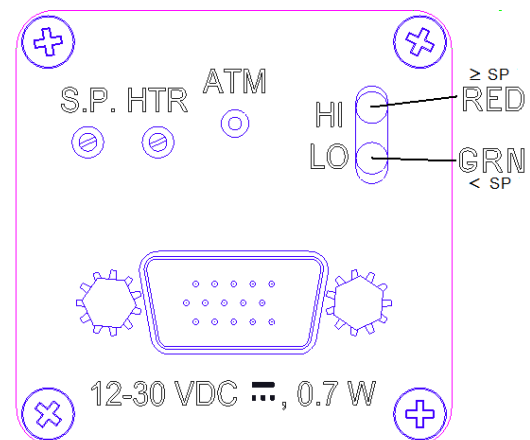

### 1.4.2 DV-6S: New DV-6 tube For Severe Environments

Hastings Instruments has developed a new gauge tube, the DV-6S, which is specifically designed for outdoor use on cryogenic tanks including railcar and tanker truck applications. In addition to the DAVC, the gauge tube is compatible with the hand-held HPM-4/6 and the analog VT-6.

The DV-6S is supplied with a protective cap. The o-ring-sealed cap protects the gauge tube pins from moisture thus significantly reducing corrosion. A metal lanyard prevents cap loss. The tube is provided with a standard 1/8" NPT fitting; however special fitting requests can often be met.

### 1.4.3 Calibration Reference Tubes

THI Reference Tubes employ the same metal thermopiles used in all THI Vacuum Gauge Tubes. The thermopile is sealed in a glass capsule that has been evacuated, baked, out-gassed, and then aged to ensure long-term stability. The sealed capsule is then housed in a protective metal shell to provide a rugged, trouble-free assembly.

Once assembled, the reference gauge tube is accurately calibrated to precisely simulate a gauge tube at a given operating pressure. It provides quick and easy instrument re-calibration by merely plugging the instrument and, in the case of the DAVC, adjusting the HTR potentiometer until the display reads the exact pressure noted on the reference tube.

#### Vacuum Gauge Tubes 1000 mTorr Range

Stock #	Model #	Description
55-38	DV-6M	1/8" NPT Standard (Yellow base)
55-38R	DV-6R	1/8" Ruggedized
55-38RS	DV-6	1/8" NPT Rohs Rugged
55-38S	DV-6S	1/8" NPT Rugged/Vibration
55-251	DV-6-KF-16	KF-16™
55-267	DV-6-KF-25	KF-25™
55-283	DV-6-VCR	VCR™
55-38R-CF	DV-6R-CF	Mini Conflat™

#### Extension Cables for VT Series (DAVC)

55-3	OM-8-OFV	8 Ft Extension Cable
55-22	OM-12-OFV	12 Ft Extension Cable
65-53	OM-25-OFV	25 Ft Extension Cable
65-102	OM-50-OFV	50 Ft Extension Cable
55-142	OM-100-OFV	100 Ft Extension Cable

#### Vacuum Gauge Tubes 20Torr Range

55-19	DV-4D	1/8" NPT (Purple Base)
55-19R	DV-4R	1/8" NPT Ruggedized
55-258	DV-4D-KF-16	KF-16™
55-266	DV-4D-KF-25	KF-25™
55-227	DV-4D-VCR	VCR™

#### Vacuum Gauge Tubes 100 mTorr Range

55-19	DV-5M	1/8" NPT (Red Base)
55-230	DV-5M -VCR	VCR™

#### Reference Tubes for use with DAVC

55-104	DB-20	Ref Tube (DV-6) for DAVC-6 Calibration
55-101	DB-16D	Ref Tube (DV-4D) for DAVC-4 Calibration
55-103	DB-18	Ref Tube (DV-5) for DAVC-5 Calibration

# 2.0 Installation

## 2.1 Power-I/O Cable

The Power-I/O Cable is assembled at the factory as shown in Fig. 1. Its terminal end is finished with stripped wire ends each tinned with lead free solder. This configuration is consistent with the previous, analog version of the AVC and its color coded wire assignment remains the same, as much as possible, considering the additional features of the Digital version.

Fig 1

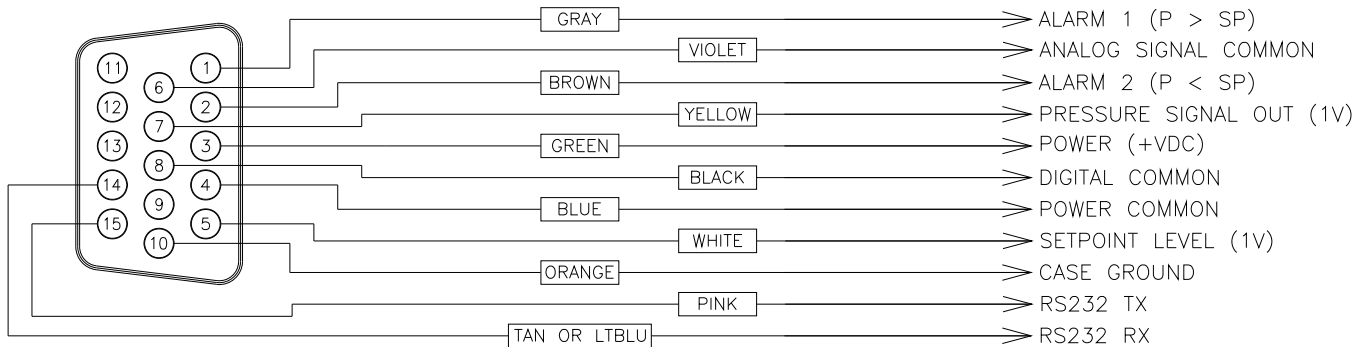

## 2.2 Power Requirements & Pin Out

Supply the DAVC with a well regulated, 12 to 30 VDC power source capable of providing at least 0.5 Watts between Power pin 4 (blue/-) and Power Common pin 3 (green/+). See Fig. 1.

## 2.3 Serial Communications Pin Out

The transmit line of the DAVC, RS232 TX pin 15 (pink), must be connected to the receive pin of the serial connector on the computer and the receive line, RS232 RX pin 14 (tan) must be connected to the transmit pin of the serial connector on the computer. A third line, Digital Common, pin 8 (black), should join the common pins on both the computer and the DAVC.

RS-232 communication may be established with baud rates of 9600 or 19200 only. The communication conditions of the DAVC are fixed at 8 data bits, 1 stop bit, no parity and no handshaking. See the SERIAL COMMUNICATIONS subsection under OPERATION for the command set.

## 2.4 Analog Output Pin Out

An analog Pressure Signal output line, pin 7 (yellow) supplies a 0 to 1 VDC signal corresponding to the output range of the selected tube. This signal should be measured with respect to the Analog Signal Common at pin 6 (violet).

## 2.5 Pressure Alarms Pin Out

A single pressure set point controls two open collector circuits. Alarm 1, the over-pressure condition is available through pin 1 (gray) and Alarm 2, the under-pressure condition available through pin 2 (brown).

The open-collector circuits will need to be supplied with power and current limiting resistance by the end user. The suggested circuit configuration is illustrated in Figure 2. The open collector circuits are limited to the Voltage limitations of the DAVC and the maximum continuous current should be limited to no more than 0.5 amps to avoid damage to the DAVC.

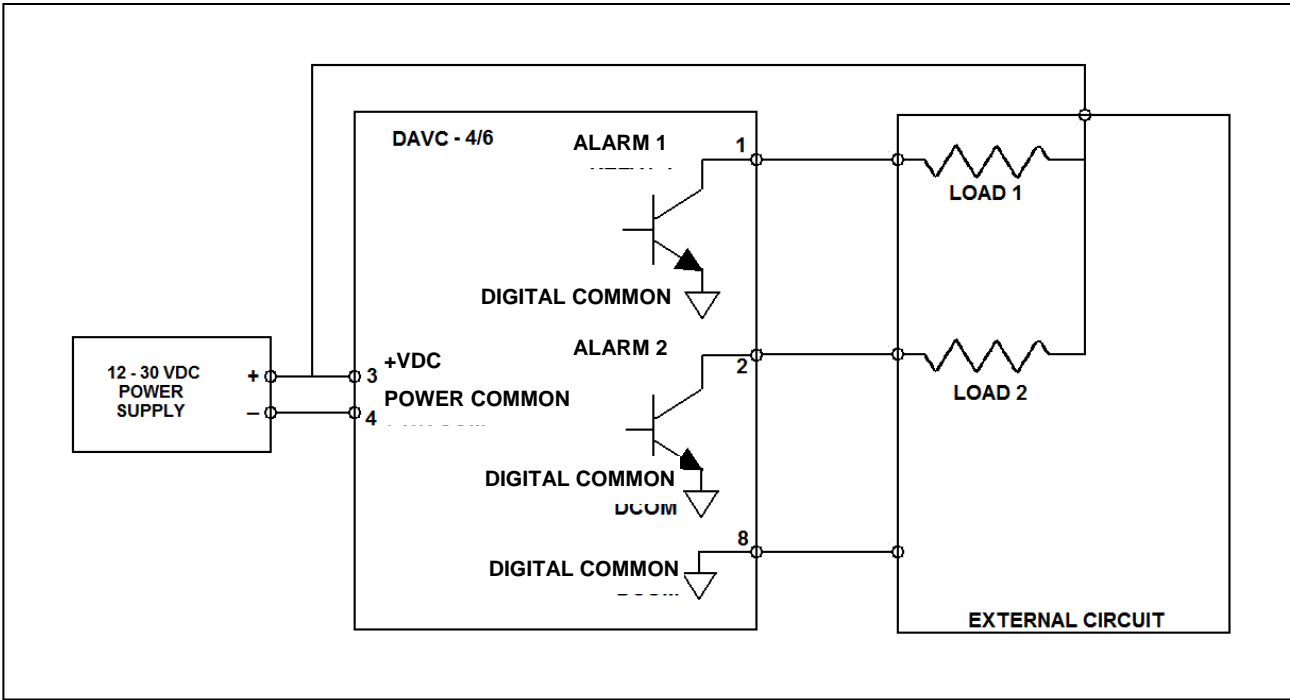

Fig. 2  
Relay Hook Up

## 3.0 Vacuum Gauge Operation

All THI gauge tubes are shipped with a protective cap or cover at the evacuation port to reduce contamination and prevent damage to the internal thermopile elements. Once the protective cap or cover is removed, a tube can be installed in any convenient position in the vacuum system without adversely affecting calibration or performance. The recommended orientation is with the tube vertical and its stem down. This will aid in preventing condensable materials from remaining in the gauge tube.

### 3.1 Quick Start

1. Install the appropriate DV4, DV5 or DV6 gauge tube (See the bottom of the instrument to determine the appropriate tube) into the vacuum system. When installing the gauge tube, consider the position of the keyed octal plug so that the LED's and controls on the DAVC will be readily accessible
2. Plug the gauge tube into the octal socket on the bottom of the Digital AVC.
3. Connect power common (-) to the blue wire (pin 4) and from +12 VDC to +30 VDC supply to the green wire (pin 3). One of the LED's indicating over-pressure or under-pressure on the top of the DAVC will illuminate.
4. While at one atmosphere, press the ATM button and release to set the atmosphere tube output for this individual tube. The LEDs will flash while the button is pressed. Holding the button longer than 3 seconds will reset the adjustment back to the default value.
5. The low pressure accuracy can be improved if the vacuum chamber can be pumped down below the minimum pressure range of the attached tube can be reached, adjust the HTR potentiometer until that pressure reading is reported (See the serial communication section) or until the analog Pressure Signal Output, pin 7 (yellow) equals approximately 1.0 Volts. Refer to Section 3.7 for more information about tube calibration.

### 3.2 Analog Pressure Measurement

An analog Pressure Signal Output line, pin 7 (yellow), supplies a 0 to 1 VDC signal corresponding to the output range of the selected tube. This signal should be measured with respect to the Analog Signal Common line, pin 6 (violet). See the INSTALLATION section for a diagram showing the Analog Signal pin out.

This signal is equal to an amplified tube millivolt signal. This signal will NOT be linearly proportional to the indicated pressure. 1 volt (1.2 for DAVC4-1.2V) will correspond to a system pressure that is at least 1 order of magnitude less than the minimum detectable pressure. Increasing pressure will be indicated by a decreasing voltage. The minimum detectable pressure is 0.2 millitorr for DAVC-5, 1 millitorr for DAVC-6 and 20 millitorr for DAVC-4.

The voltage signal can be mapped to a pressure value by using the following equation.

$$P = \frac{a + cV + eV^2}{1 + bV + dV^2}$$

Where:

V = Voltage

P = pressure in Torr for DV4 & DV5 versions and millitorr for DV6

Parameters	DV6	DV4	DAVC-4-1.2V	DV5
a	-1623.22	-5.10184	-3.8115614	-0.25948
b	-58.0442	-6.91233	-2.5905928	-42.23869
c	-11732.2	-4.4943	-26.238798	-2.92598
d	-130.397	-6.30995	-22.881611	-256.99510
e	13338.17	9.563177	24.483441	3.18016

### Analog Output vs Pressure

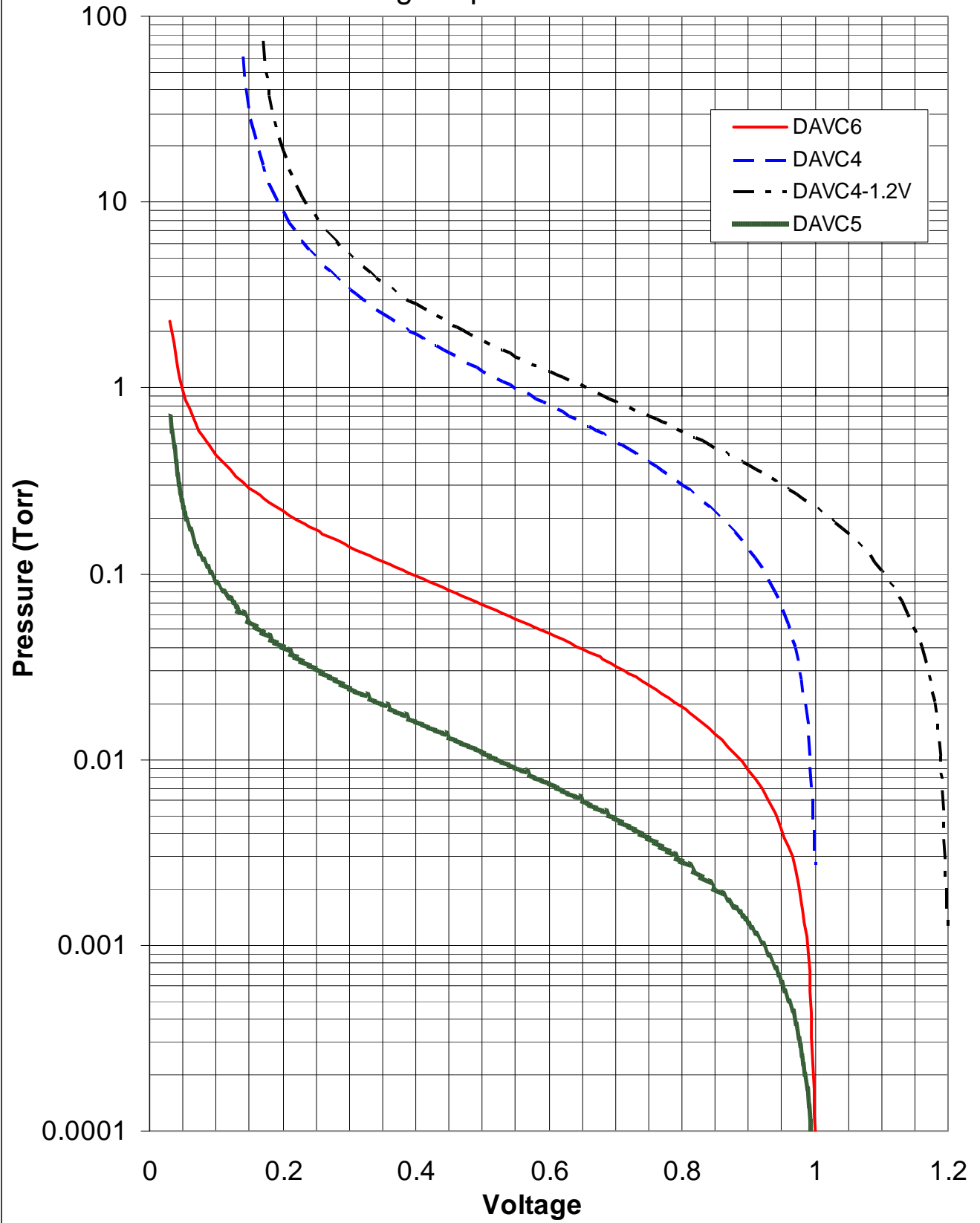

### 3.3 Alarm Set point

A single set point controls two open collector circuits. Though not the mechanical relays, the two circuits called Alarm 1 ( $P > SP$ ) and Alarm 2 ( $P < SP$ ) allow physical monitoring of the state of the vacuum with respect to the set point.

Alarm 1 ( $P > SP$ ), pin #1 (gray), is active when the red LED is 'ON' indicating that the pressure is above the set point.

Alarm 2 ( $P < SP$ ), Pin #2 (brown), is active when the green LED is 'ON' indicating that the pressure is below the set point.

The open-collector circuits need to be supplied with their own power and current limiting resistance by the end user. The load, controlled by the Open-Collector circuits, must not require voltages higher than those specified for the DAVC (12 – 30 VDC) AND must not exceed 500 mAmps of continuous current. See the section on Pressure Alarms Pin Out for wiring instructions.

The alarm set point may be set in one of two ways:

One, by the measuring the Voltage signal between Analog Signal Common, Pin #6 (violet) and Setpoint Level, Pin #5 (white) and setting the voltage using the SP potentiometer until the voltage corresponds to the pressure indicated on one of the Pressure Vs. Voltage charts above.

Two, by using the A2 command to send the set point voltage to the A/D converter in conjunction with a P1 command to enable streaming while the pot is set to the desired trigger pressure. Remember to disable streaming by issuing a P0 command and reset the signal source of the A/D converter by issuing an A0 command.

While the SP potentiometer is enabled using the PE command, the value of the set point is read every thirty seconds and compared to its previous setting. If the setting has changed, the new setting will be stored to non-volatile memory. If the SP potentiometer is disabled using the PD command, then no tweaking of the SP potentiometer will have any affect.

In either Enabled (PE) or Disabled (PD) cases, using the S1=#.## command will re-write a new set point. Only if the Potentiometer is Enabled using the PE command, will adjustment of the potentiometer affect a previous set point.

### 3.4 Digital Communications.

See the section on Serial Communications Pin Out for wiring instructions. RS-232 communication may be established with baud rates of 9600 or 19200 only. The communication parameters of the DAVC are fixed at 8 data bits, 1 stop bit, no parity and no handshaking. The command set can be found in the table below. Communication with the serial interface of the Digital AVC is via an ASCII data string. The command message consists only of a command string and the terminator. If all components of the ASCII data string are valid the command will be accepted and executed.

#### 3.4.1 Command Syntax.

In the following examples of syntax codes, the special characters are explained:

The first characters in each row of the format column represent a command string, either upper or lower case command characters accepted. All characters must follow each other in the string with no spaces or other characters.

The characters within wavy brackets { } contain choices for the appropriate command.

The characters within the symbols < > are the common abbreviations for the one digit ASCII control codes which they represent, (e.g. <CR> represents carriage return).

All command strings must be followed by the terminator character (carriage return <CR>, also known as ENTER).

When a lower case character is present in an example it represents an option.

Character	Description	Valid Inputs:
m	Most Significant Digit Of Mantissa	1 - 9
d	Decimal Digit	0 - 9
e	Exponent	0 - 5
<CR>	Command Terminator (carriage return)	N/A

### 3.4.2 Interrogation Commands.

<u>Command Description</u>	<u>Format</u>	<u>Sample Response</u>
Get Device ID	ID<CR>	Digital AVC<CR>
Get Current Pressure if A0 is set, current Set Point if A2 is set, heater potentiometer setting if A3 is set	P<CR>	Pa: 1.23456e+0 Torr<CR>
Get Relay Status	RS<CR>	1,R1:ON<CR>
Get Setpoint	S1<CR>	SP1: 1.0240e-2 mbar<CR>
Get Serial Number (10 character max)	SN<CR>	1023400012<CR>
Get Sensor Type	ST<CR>	DV-6<CR>
Get Raw Average Output Voltage – No Offset.	U<CR>	Vavg: 1.23456e-1 Volts<CR>
Get User Data (10 character max)	UD<CR>	TextString<CR>
Get Software Version #	V<CR>	Digital CVT 1.1.0 <CR>

### 3.4.3 Parameter Modification Commands

<u>Command Description</u>	<u>Format</u>	<u>Response</u>	<u>notes:</u>
Select A/D input 0	A0<CR>	none	Read from gauge tube
Select A/D input 1	A1<CR>	none	Read from Setpoint Potentiometer
Select A/D input 2	A2<CR>	none	Read heater adjust potentiometer
Data streaming/Logging Off	P0<CR>	none	Stops streaming output
Data streaming/Logging On	P1<CR>	See P cmd	(Reports signal Voltage and pressure in Torr only)
Disable set-point pot.	PD<CR>	OK	Lock out local setpoint adjustment
Enable set-point pot.	PE<CR>	OK	Enable local setpoint adjustment
Modify Setpoint	S1={m.dd}E{+e}<CR>	OK	1.00000e-9 to 9.99999e+9
Set units to Torr	U1<CR>	OK	All subsequent values in Torr
Set units to Pascal	U2<CR>	OK	All subsequent values in Pascal
Set units to Mbar	U3<CR>	OK	All subsequent values in mbar
Modify User Data	UD=TextString<CR>		10 character maximum

#### Notes:

The User Data is 10 digit text area reserved for use by the customer for identification purposes.

The setpoints may also be entered as a decimal number, e.g. [S1=0.760<CR>] will be same as entering [H=7.60E-1<CR>].

When inputting setpoint data, it should be entered in the same Units of Pressure as the presently selected Units of Measurement (i.e. Torr, mbar or Pascal). The data is only checked to be a valid number with a one

digit exponent before being accepted. There are no limit checks on the data; the user is free to choose any value appropriate to his use of the instrument.

If the command syntax is not met or if the number is out of range, the Digital AVC will respond with the ASCII codes for <bell>?<CR>, and the command will be ignored.

### 3.4.4 Reset / Initialize Commands

Command Description Format	Notes:
Software Reset /<CR> Does not reset or overwrite any parameters saved in non-volatile memory (EEPROM).	Reset instrument
Autobaud <ctrl-z><CR>	Match baud rate currently in use

Device can run at 9600 or 19200 Baud. Set terminal to 9600/N/8/1 or 19200/N/8/1 and type Ctrl-Z.

The <ctrl-z> is entered by holding down the "Ctrl" key while pressing the "z" key when using terminal emulator program. This character has an ascii code of 26 (decimal) and 1A (hexadecimal).

Device will respond with Device ID (Digital AVC). If this response is not generated, repeat the Ctrl-Z until it is. The Baud rate will be stored in EEPROM and is remembered on the next power-up.

## 3.5 Operation and Performance

The Digital AVC will function right "out of the box". For maximum accuracy refer to the Calibration section below and perform the calibration procedure.

The simplest and quickest way of checking the operation and performance of a gauge and/or gauge tube, is to keep a new or known-good gauge tube on hand for use as a reference.

To check operation, install both the reference and suspect gauge tubes in a common vacuum system (locate the gauge tubes as close as possible to each other), then evacuate the system until a stable base pressure is obtained. Alternately connect the vacuum gauge to each gauge tube and record its pressure readings. If the gauge tube-under-test produces a significantly higher pressure reading than the reference gauge tube, this indicates a calibration shift and is usually the result of contamination (particulate, oil, or other chemical deposits). You can try to restore calibration of the contaminated gauge tube by cleaning it internally with an appropriate solvent such as high-purity isopropyl alcohol (flood the interior cavity of gauge tube gently with solvent and allow it to stand and soak for about 15 to 30-minutes). Drain the contaminated solvent and let gauge tube dry in ambient air until all of the cleaning solvent has evaporated. To prevent mechanical damage to the thermopile elements, do not use forced air to dry the gauge tube. Gauge tubes that remain out of calibration after cleaning should be replaced.

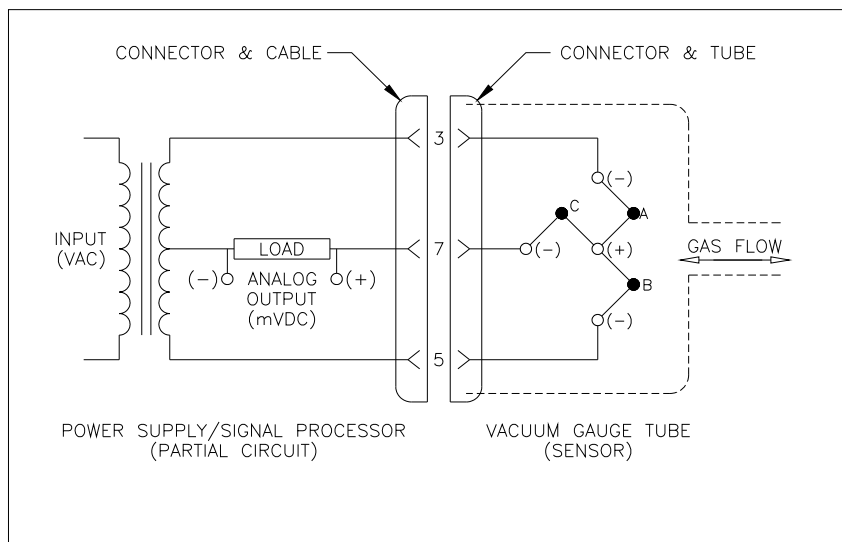

## 3.6 Gauge Tube Operating Principle

Operation of the Hastings gauge tube is based on a low voltage AC bridge that heats a noble metal thermopile. A change in pressure in the gauge tube changes the molecular collision rate and therefore the thermal conduction of the gas or gas mixture surrounding the thermopile. This results in a temperature shift in the AC heated thermocouples A and B (Fig. 6). The resultant temperature shift causes a change in the DC output from couples A and B inversely with pressure changes. The DC thermocouple C (when installed) is in series with the circuit load. Thermocouple C provides compensation for transient changes in ambient temperature.

## 3.7 Calibration Procedure

NOTE: ONCE CALIBRATION IS COMPLETE THE CALIBRATION DATA IS PERMANENTLY STORED IN NON-VOLATILE MEMORY. A LOSS OF POWER WILL NOT ERASE THE CALIBRATION DATA. TO ERASE THE CALIBRATION DATA, REFER TO STEP 2.

### 3.7.1 Preparation

1. The following procedures can be carried out on a unit installed in a vacuum system as long as a calibrated reference meter is installed in the same system in close proximity to the unit being calibrated.
2. The following procedure assumes that the appropriate DV4, DV5 or DV6 gauge tube (See the bottom of the instrument to determine the appropriate tube) corresponding to the set up of the DAVC is connected to the unit.
3. Power the DAVC with a DC supply capable of providing from 12 to 30 Volts DC and at least 0.5 Amps.
4. Using a pointed object, such as a ballpoint pen, press and hold the "ATM" push button located on the top cover until the two LEDs are on continuously (approximately 3 seconds). This deletes any previously stored data.

### 3.7.2 Set High End

NOTE: TUBE MUST BE AT ATMOSPHERE TO PROPERLY SET THE HIGH END.

While at one atmosphere, press the ATM button and release to set the atmosphere tube output for this individual tube. The LEDs will flash while the button is pressed. Push the button only as long as it takes the LED's to blink one or twice. Holding the button longer than 3 seconds will reset the adjustment back to the default value. The high-end setting is now set.

### 3.7.3 Set Low End W/Vacuum System

NOTE: The LOW END can be adjusted by either bringing the system to a known vacuum or by using a HASTINGS REFERENCE TUBE (see below).

- A. Set system to known vacuum.
- B. Turn the HTR potentiometer on the top panel until the either the voltage measured between pins 6, Analog Signal Common (violet) and 7, Pressure Signal Output (yellow) reads the voltage corresponding to the pressure as read on the Pressure Vs. Voltage chart for the tube being measured or, if using serial communication, until the proper pressure is read while using the streaming P1 command.
- C. The low end is now adjusted.

### 3.7.4 Set Low End W/Reference Tube.

- A. Connect the THI reference tube.

- B. Turn the HTR potentiometer on the top panel until the either the voltage measured between pins 6, Analog Signal Common (violet) and 7, Pressure Signal Output (yellow) reads the voltage corresponding to the pressure as read on the Pressure Vs. Voltage chart for the tube being measured or, if using serial communication, until the proper pressure is read while using the streaming P1 command.
- C. THE LOW END is now adjusted.

NOTE: If re-calibration is required you must repeat the High End adjustment first.

The following table specifies the THI reference tube to be used in the calibration of a gauge based upon the type of gauge tube being used.

<b>Ref. Tube</b>	<b>Gauge Tube</b>
DB-16D	DV-4
DB-18	DV-5
DB-20	DV-6

# 4.0 Warranty

## 4.1 Warranty Repair Policy

Hastings Instruments warrants this product for a period of one year from the date of shipment to be free from defects in material and workmanship. This warranty does not apply to defects or failures resulting from unauthorized modification, misuse or mishandling of the product. This warranty does not apply to batteries or other expendable parts, nor to damage caused by leaking batteries or any similar occurrence. This warranty does not apply to any instrument which has had a tamper seal removed or broken.

This warranty is in lieu of all other warranties, expressed or implied, including any implied warranty as to fitness for a particular use. Hastings Instruments shall not be liable for any indirect or consequential damages.

Hastings Instruments, will, at its option, repair, replace or refund the selling price of the product if Hastings Instruments determines, in good faith, that it is defective in materials or workmanship during the warranty period. Defective instruments should be returned to Hastings Instruments, **shipment prepaid**, together with a written statement of the problem and a Return Material Authorization (RMA) number. Please consult the factory for your RMA number before returning any product for repair. Collect freight will not be accepted.

## 4.2 Non-Warranty Repair Policy

Any product returned for a non-warranty repair must be accompanied by a purchase order, RMA form and a written description of the problem with the instrument. If the repair cost is higher, you will be contacted for authorization before we proceed with any repairs. If you then choose not to have the product repaired, a minimum will be charged to cover the processing and inspection. Please consult the factory for your RMA number before returning any product repair.

TELEDYNE HASTINGS INSTRUMENTS  
804 NEWCOMBE AVENUE  
HAMPTON, VIRGINIA 23669 U.S.A.  
ATTENTION: REPAIR DEPARTMENT  
TELEPHONE (757) 723-6531  
1-800-950-2468  
FAX (757) 723-3925  
E MAIL [mailto:hastings\\_instruments@teledyne.com](mailto:hastings_instruments@teledyne.com)  
INTERNET ADDRESS <http://www.teledyne-hi.com>

Repair Forms may be obtained from the "Information Desk" section of the Hastings Instruments web site.