



Hastings Instruments

# Digital CVT

## INSTRUCTION MANUAL



### Use and Disclosure of Data

Information contained herein is classified as EAR99 under the U.S. Export Administration Regulations. Export, reexport or diversion contrary to U.S. law is prohibited.

## Manual Print History

The print history shown below lists the printing dates of all revisions created for this manual. The revision level letter increases alphabetically as the manual undergoes subsequent updates. Each new revision includes a revised copy of this print history page.

Revision A (Document Number 173-102008)	October 2008
Revision B (Document Number 173-022009)	February 2009
Revision C (Document Number 173-072009)	July 2009
Revision D (Document Number 173-102009)	October 2009
Revision E (Document Number 173-082010)	August 2010
Revision F (Document Number 173-012011)	January 2011
Revision G (Document Number 173-032011)	March 2011
Revision H (Document Number 173-122011)	December 2011
Revision J (Document Number 173-012013)	January 2013
Revision K (Document Number 173-022013)	February 2013
Revision L (Document Number 173-012014)	January 2014
Revision M (Document Number 173-082018)	August 2018
Revision N (Document Number 173-102022)	October 2022
Revision P (Document Number 173-042024)	April 2024
Revision Q (Document Number 173-122025)	December 2025



Visit [www.teledyne-hi.com](http://www.teledyne-hi.com) for WEEE disposal guidance.

### Description of Symbols and Messages used in this manual



**WARNING:** indicates a hazardous situation, which, if not avoided, could result in death or serious injury. Do not proceed beyond a WARNING notice until the indicated conditions are fully understood.



**CAUTION:** indicates a hazardous situation, which if not avoided, could result in minor or moderate injury. Do not proceed beyond a CAUTION notice until the indicated conditions are fully understood and met.



**NOTICE:** calls attention to a procedure or practice that if not correctly performed or adhered to, could result in equipment damage, loss of data, or inaccurate data.



**NOTE:** is used for tips and other digressions.

---

Hastings Instruments reserves the right to change or modify the design of its equipment without any obligation to provide notification of change or intent to change.

---

# Table of Contents

<b>1. GENERAL INFORMATION</b>	<b>5</b>
1.1. FEATURES	6
1.2. SPECIFICATIONS	6
1.3. RELEVANT CE STANDARDS	7
1.4. ACCESSORIES	7
1.4.1. <i>Installation Accessories</i>	7
1.4.2. <i>Calibration Reference Tubes</i>	7
1.4.3. <i>Accessories Index</i>	8
<b>2. ELECTRICAL CONNECTIONS</b>	<b>9</b>
2.1. TERMINAL BLOCK	9
2.2. RELAY CONNECTION	9
2.3. DIGITAL CONNECTION	9
2.3.1. <i>Serial Communication Settings</i>	10
2.4. ANALOG OUTPUT CONNECTION	10
2.4.1. <i>Nonlinear Analog Output</i>	10
2.4.2. <i>Linear Analog Output</i>	10
2.4.3. <i>Current Loop Additional Information</i>	10
2.4.4. <i>DC Power Output Offset</i>	10
<b>3. VACUUM GAUGE OPERATION</b>	<b>11</b>
3.1. AC INPUT POWER	11
3.2. QUICK START	11
3.3. PRESSURE MEASUREMENT	12
3.4. OPERATION AND PERFORMANCE	12
3.4.1. <i>Troubleshooting</i>	12
3.4.2. <i>Cleaning a Gauge Tube</i>	12
3.5. GAUGE TUBE OPERATING PRINCIPLE	12
3.6. LINEAR OUTPUT SELECTION	13
3.7. TUBE SELECTION	13
3.8. CALIBRATION PROCEDURE	14
3.8.1. <i>Preparation</i>	14
3.8.2. <i>Set High End</i>	14
3.8.3. <i>Set Low End with Vacuum System</i>	14
3.8.4. <i>Set Low End with Reference Tube</i>	14
3.8.5. <i>Multiple Tubes</i>	15
3.9. SET RELAY TRIGGER POINTS	15

*Digital CVT Instruction Manual*

- 3.9.1. *Hysteresis* ..... 15
- 3.9.2. *Reading / Changing Setpoints Locally*..... 15
- 3.9.3. *Reading / Changing Setpoints Remotely* ..... 15
- 3.9.4. *Locking Relays On or Off* ..... 15
- 3.10. LINEAR OUTPUT CALIBRATION ..... 16
  - 3.10.1. *Setup* ..... 16
  - 3.10.2. *Procedure*..... 16
- 3.11. ANALOG OUTPUT INTERPRETATION ..... 17
  - 3.11.1. *Non-Linear Analog Output Interpretation* ..... 17
  - 3.11.2. *Linear Output Interpretation*..... 19
- 3.12. PRESSURE UNITS ..... 22
- 3.13. THERMAL COEFFICIENT ..... 23
- 3.14. DIGITAL COMMUNICATIONS ..... 23
  - 3.14.1. *Command Syntax* ..... 23
  - 3.14.2. *Interrogation Commands* ..... 24
  - 3.14.3. *Parameter Modification Commands* ..... 24
  - 3.14.4. *Linear Commands* ..... 25
  - 3.14.5. *Linear Status Output* ..... 25
  - 3.14.6. *Reset / Initialize Commands*..... 25
  - 3.14.7. *Device Status*..... 26
- 4. **WARRANTY AND REPAIR** ..... 27
  - 4.1. WARRANTY REPAIR POLICY ..... 27
  - 4.2. RETURN POLICY ..... 27
- 5. **DRAWINGS AND INSTALLATION** ..... 28
  - 5.1. DCVT OUTLINE DIMENSIONS ..... 28
  - 5.2. DCVT FRONT PANEL ..... 29
  - 5.3. DCVT BACK PANEL ..... 29
  - 5.4. DCVT MOUNTING ..... 29
  - 5.5. DCVT-33D OUTLINE DRAWINGS ..... 30

# 1. General Information

This manual contains technical and general information relating to the installation, operation, and calibration of Teledyne Hastings Vacuum Gauges, and Gauge Tubes.

For best performance, Hastings vacuum gauges should be operated with the appropriate Hastings gauge tube. Attempting to use a Hastings vacuum gauge with other manufacturer's tubes may result in damage to both the gauge and tube.



**NOTICE:** The instruments described in this manual are designed for INDOOR and DRY use only.



**NOTICE:** The instruments described in this manual are designed for Class 2 installations in accordance with IPC standards.



**CAUTION:** There are no operator serviceable parts or adjustments inside the product.



**CAUTION:** If this equipment is used in a manner other than that specified, the protection provided by the equipment may be impaired.

## 1.1. Features

The Teledyne Hastings Instrument's Digital CVT (DCVT), is a digital readout version of the successful CVT-Series "Hastings Gauge" which has generated loyal customers for many years. A reputation has been built on exceptional stability, accuracy, and reliability. This instrument has been designed for laboratory or light industrial applications, but it is not suitable for outdoor or heavy industrial areas where spraying liquid or wash-downs may occur.

A precision A/D converter and microprocessor measure and convert the gauge tube's output signal using the tube's well-defined output/pressure function, and a three-digit display presents the result.

The Hastings DCVT offers an analog output signal on pins 1 and 2 of the terminal block. This analog output signal can be configured in six different options (see 2.4, 3.6, 3.14.4): Nonlinear 0-1V, or linear 0-1V, 0-5V, 0-10V, 0-20mA, or 4-20mA. The current pressure reading can also be acquired digitally through the RS232 port. The dual control points (setpoints) are durable 10-amp single pole double throw relays which can be configured normally open or normally closed (Relay 1 = pins 7-9, Relay 2 = pins 10-12).

The Digital CVT Vacuum Gauge Meter was designed for long life and minimal maintenance. The DCVT utilizes Teledyne Hastings rugged noble metal thermocouple gauge tubes which are designed for specific pressure ranges. Tubes are matched and interchangeable without calibration adjustments. They are compensated for temperature, rate of temperature change and are corrosion resistant. The table below describes the pressure ranges for the DV-4, DV-5, and DV-6 gauge tube families that can be used with the DCVT.

Gauge Tube	Pressure Range
DV-4	0.2-20 Torr
DV-5	0.1-100 mTorr
DV-6 & DV-33	1-999 mTorr

## 1.2. Specifications



**WARNING:** Do not operate instruments exceeding the specifications listed below. Failure to heed this warning could result in serious personal injury and/or damage to the equipment.

### Digital CVT Vacuum Meter:

Accuracy	DV-4, $\pm(20\%$ of Reading + 0.01 Torr) DV-5, $\pm(20\%$ of Reading + 0.2 mTorr) DV-6 & DV-33, $\pm(15\%$ of Reading + 0.001 Torr)
Input Power	90-250 VAC, 6 Watts (Max) or optionally 22-25 VDC, 2 Watts (Max)
Cables (Approx.)	6-ft. power cable and 8-ft. sensor cable included
Pressure Units	DV-4 - Torr, DV-5 - mTorr, DV-6 - mTorr, DV-33 - mTorr Optionally mbar, Pascal
Weight (Approx.)	0.7 lbs. (0.3 kg)
Operating Temperature	-20 - 70°C (non-condensing environment)
Relays	Max switching voltage 250 VAC, 100 VDC Max switching current 10 Amps (AC), 5 Amps (DC) Min DC switching 5 VDC/100 mA

Non-linear Analog Output	0-1 VDC
Linear Analog Output	0-1, 0-5, 0-10 VDC, and 0-20, 4-20 mA
Digital Output	RS232 (9600 / 19.2k baud) (6-pin modular connector)
Tube Signal	0-10 mV DC, (Compatible with DV-4, DV-5, DV-6 tubes)
AC Connection	IEC-320
Analog Out, Tube Drive, Tube Input, Relay Connections, 24 VDC	12 pin terminal block
Serial Port	6 pin modular connector



**NOTICE:** Use of an underpowered or under-voltage supply could result in equipment damage.



**WARNING:** Do not power with isolated drive circuits that are more than 36 volts above ground potential or could reach 36 volts in the event of a fault. Failure to heed this warning could result in serious personal injury and/or damage to the equipment.

### 1.3. Relevant CE Standards

Test	Standard	Test	Standard
Safety	EN61010	Fast Transients	EN61000-4-4
EMC/EMI Family	EN61326	Surge	EN61000-4-5
Conducted/Radiated	EN55011	Conducted Immunity	EN61000-4-6
ESD	EN61000-4-2	Voltage Dips	EN61000-4-11
RF	EN61000-4-3		

### 1.4. Accessories

#### 1.4.1. Installation Accessories

Teledyne Hastings Instruments offers a complete line of system attachments that permit easy maintenance for contaminated operations. Gauge tubes are offered with various system fittings to match almost any system requirement. Additionally, Teledyne Hastings' complete line of quick disconnect attachments allows customers to install these special fittings and easily replace sensors without vacuum sealant or Teflon® tape. For particularly dirty systems, Teledyne Hastings offers a particle dropout trap containing a series of nine separate baffles which prevent solid contaminants from having a direct path to the sensor's thermopile.

#### 1.4.2. Calibration Reference Tubes

Teledyne Hastings Instruments Reference Tubes employ the same Hastings metal thermopiles used in all Teledyne Hastings Vacuum Gauge Tubes. The thermopile is sealed in a glass capsule that has been evacuated, baked, outgassed, and aged to ensure long-term stability. The sealed capsule is housed in a rugged metal shell to provide a trouble-free assembly. The reference gauge tube is calibrated to simulate a gauge tube at a given operating pressure and provides quick and easy adjustment. DCVT re-calibration is accomplished by simply adjusting the zero potentiometer until the display reads the exact pressure noted on the reference tube.

### 1.4.3. Accessories Index

#### Vacuum Gauge Tubes and Cables

##### Gauge Tubes - 20 Torr Range

Stock #	Model #	Description
55-19	DV-4D	20 Torr Vac Gauge Tube (Purple Base)
55-19R	DV-4R	20 Torr Vac Gauge Tube/Rugged
55-258	DV-4D-KF-16	20 Torr Vac Gauge Tube/KF-16™
55-266	DV-4D-KF-25	20 Torr Vac Gauge Tube/KF-25™
55-227	DV-4D-VCR	20 Torr Vac Gauge Tube/VCR™
55-69	DV-34	20 Torr Vac Gauge Tube/316SS
55-101	DB-16D	Ref Tube (DV-4D) for VT-4 Calibration

##### Gauge Tubes - 100 mTorr Range

55-19	DV-5M	1/8" NPT (Red Base)
55-230	DV-5M -VCR	VCRTM
55-103	DB-18	Ref Tube (DV-5M) for VT-5 calibration

##### Gauge Tubes - 1000 mTorr Range

55-38	DV-6M	1000 mTorr (Yellow Base)
55-38R	DV-6R	1000 mTorr Vac Gauge Tube/Rugged
55-38S	DV-6S	1000 mTorr Vac Gauge Tube/Rugged w/ cap
55-251	DV-6-KF-16	1000 mTorr Vac Gauge Tube/KF-16™
55-267	DV-6-KF-25	1000 mTorr Vac Gauge Tube/KF-25™
55-283	DV-6-VCR	1000 mTorr Vac Gauge Tube/VCR™
55-38R-CF	DV-6R-CF	1000 mTorr Vac Gauge Tube/Mini Conflat™
55-66	DV-36	1000 mTorr Vac Gauge Tube/316SS
55-104	DB-20	Ref Tube (DV-6) for VT-6 Calibration

##### Digital CVT Cables

CB-DCVT-8	-	Cable, Digital CVT, 8' (std)
CB-DCVT-25	-	Cable, Digital CVT, 25'
CB-DCVT-XXX	-	Cable, Digital CVT, Special/custom length

##### Extension Cables for VT Series (DVT & DCVT)

55-3	OM-8-OFV	8 Ft Extension Cable
55-22	OM-12-OFV	12 Ft Extension Cable
65-53	OM-25-OFV	25 Ft Extension Cable

## 2. Electrical Connections

The following sections detail the connections and pinouts between the terminal block (including the relay connections and analog out), the modular connector (for digital communications), and the 1 by 3 jumper (linear vs nonlinear analog output).

### 2.1. Terminal Block

The pinout for the terminal block is as follows:

Pin #	Description
1	Analog Out
2	Common
3	24 VDC
4	Tube - Green
5	Tube - White
6	Tube - Black
7	Relay 1 - NC
8	Relay 1 - Common
9	Relay 1 - NO
10	Relay 2 - NC
11	Relay 2 - Common
12	Relay 2 - NO

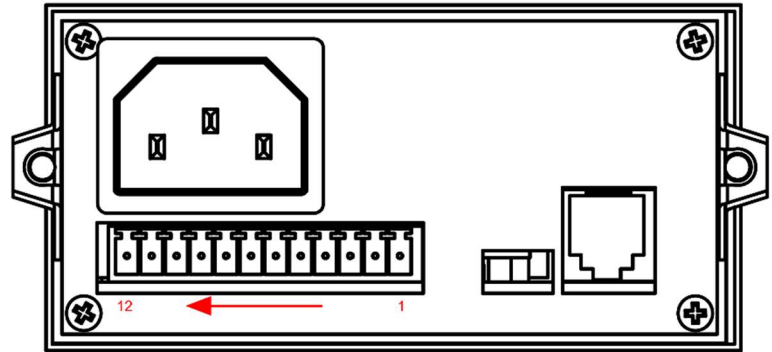

### 2.2. Relay Connection

There are two relays installed in the DCVT. Each relay can be set to trigger independently. Both relays are setup to be de-energized at high pressure and to energize when indicated pressure is below the setpoint. Normally-open (NO), common and normally-closed (NC) terminals are available for each relay on the rear terminal block. The normally-open contact for Relay1 (terminal 9) will connect to the common terminal for Relay1 (terminal 8) when the indicated pressure is less than the setpoint. The normally-closed contact for Relay1 (terminal 7) will be connected to the common terminal for Relay1 whenever the pressure is greater than the setpoint or when power is lost. The contacts for Relay2 operate similarly. These connections can be used to start/stop pumps, ion gauges or to open/close system valves at selected pressures. The specifications for the switching capability can be found in 1.2.

### 2.3. Digital Connection

The Digital CVT uses an RJ12 modular connector (6P6C). The pins are numbered looking into the female connector with the pins on the top from left to right. Note that the TX pin is defined as signals being transmitted from the Digital CVT to the bus master while the RX pin is defined as signals being received by the Digital CVT Series from the bus master. Teledyne Hastings offers a preassembled cable that will interface between a Digital CVT and a standard 9 pin computer serial port (#CB-RS232-RJ12). If making up a cable to interface to the standard 9-pin serial port use the following connections:

See the table below for the standard pin-out:

RJ12 Pin #	Description	D9 Pin #
1	NC	-
2	TX	2
3	Common	-
4	Common	5
5	RX	3
6	NC	-

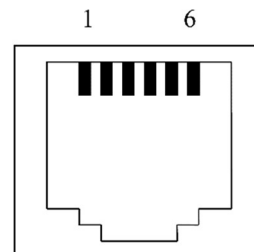

### 2.3.1. Serial Communication Settings

The default port set-up is 19.2K baud, 8 data bits, no parity, and no flow control. If the instrument receives a Ctrl-Z (hex 1A, decimal 26) character it will automatically set itself to the baud rate of the port. The <ctrl-z> is entered by holding down the “Ctrl” key while pressing the “z” key when using terminal emulator program.

## 2.4. Analog Output Connection

The Digital CVT may be configured to have one of several types of analog outputs available on pins 1 and 2 of the terminal block.

### 2.4.1. Nonlinear Analog Output

The nonlinear output is a 0 - 1 volt signal, which is equal to an amplified tube millivolt signal. This signal will NOT be linearly proportional to the indicated pressure. Output of 1 V will correspond to a system pressure that is less than 1 mTorr. Increasing pressure will be indicated by a decreasing voltage. The load resistance connected to these terminals must be kept above 2 k $\Omega$ . See Section 3.11 ANALOG OUTPUT INTERPRETATION.

### 2.4.2. Linear Analog Output

The Digital CVT can also be configured for one of the following linear analog outputs: 0-1 V, 0-5 V, 0-10 V, 0-20 mA and 4-20 mA. See Sections 3.6, 3.10 and 3.14.4. These voltage and current outputs will increase linearly with increasing system pressure.

### 2.4.3. Current Loop Additional Information

The current loop output is useful for remote applications where pickup noise could substantially affect the stability of the voltage output or long cable runs where cable resistance would cause a voltage signal to decay. The current loop signal replaces the voltage output on pin 1 of the terminal block. The current loop is sourced internally and must be returned to common on pin 2 after passing through the monitoring circuitry to complete the loop. The load must be between 0 and 1200  $\Omega$ .

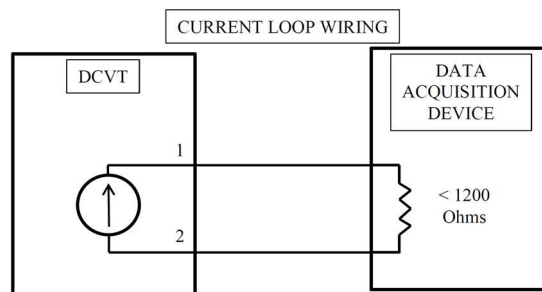

### 2.4.4. DC Power Output Offset

If the instrument is being powered through the 24 VDC pin on the rear terminal board instead of with AC power, the analog output may have an offset of 63 millivolts due to the voltage drop created by the supply current.

## 3. Vacuum Gauge Operation

All Teledyne Hastings gauge tubes are shipped with a protective cap or cover at the evacuation port to reduce contamination and prevent damage to the internal thermocouple elements. Once the protective cap or cover is removed, a tube can be installed in any convenient position in the vacuum system without adversely affecting calibration or performance. The recommended orientation is with the tube vertical and its stem down. This will aide in preventing condensable materials from remaining in the gauge tube.

### 3.1. AC Input Power

The Digital CVT uses an IEC-320 power cable. To operate the Digital CVT, plug the power cable into the connector located in the rear of the Digital CVT. Connect the plug of the power supply into a single phase 90 - 250 VAC 50/60 Hz power source.



**NOTICE:** The Power Supply Adaptor for the DCVT is rated as consuming 0.05 Amps @ 120VAC (<0.12 Amps @ 90 VAC).

### 3.2. Quick Start

#### Quick Start Instructions

1. *If mounting in an instrument panel, disconnect power to the panel.*
2. *Plug the Gauge Tube Cable (terminal block) into the connector on the rear of the DCVT.*
3. *Connect the other end of the Gauge Tube Cable (Octal Socket) to a DV4, DV5 or DV6 gauge tube.*
4. *Connect Digital CVT power cable into the connector on the rear of the DCVT.*
5. *Connect the power cord into a 90 - 250 VAC. 50/60 Hz outlet source.*
6. *If panel mounting, reconnect power to the instrument panel.*
7. *Let the CPU do a self-check/initialization. The digital display should count up and stop momentarily at FFF (If display shows "rHi" or "rLo", instrument is out of range or tube is unplugged).*
8. *The Torr and mTorr LEDs should also momentarily light up.*
9. *After CPU starts up, the display should indicate the output of the DV-4 or DV-6 tube.*
10. *Instrument is ready for operation.*
11. *If instrument needs further adjustment, see section 3.8*



Readings out of range/tube unplugged.

### 3.3. Pressure Measurement

Connect the gauge tube cable's octal socket onto the octal base of a gauge tube installed in vacuum system and plug the power supply into wall outlet. The gauge will display the system pressure on the Digital CVT. To check the accuracy of the gauge, perform the required operations as specified in section 3.8.

### 3.4. Operation and Performance

The Digital CVT will be calibrated at the factory. Recalibration is not required. For maximum accuracy refer to section 3.8 CALIBRATION PROCEDURE.

#### 3.4.1. Troubleshooting

The simplest and quickest way of checking the operation and performance of a gauge and/or gauge tube, is to keep a new, or known-good gauge tube on hand for use as a Reference. To check operation, install both a reference vacuum gauge and unit under test gauge tubes in a common vacuum system (locate the gauge tubes as close as possible to each other), then evacuate the system until a stable base pressure is obtained. Alternately connect the vacuum gauge to each gauge tube and record its pressure readings. If the gauge tube-under-test produces a higher pressure reading than the Reference gauge tube then a calibration shift has occurred, usually as the result of contamination (particulate, oil, or other chemical deposits).

#### 3.4.2. Cleaning a Gauge Tube

You can try to restore calibration of the contaminated gauge tube by cleaning it internally with an appropriate solvent such as high-purity isopropyl alcohol (flood the interior cavity of gauge tube gently with solvent and allow it to stand and soak for about 15 to 30-minutes). Drain the contaminated solvent and let gauge tube dry in ambient air until all the cleaning solvent has evaporated. **DO NOT use forced air to dry the gauge tube!** This will damage the thermocouple elements. Gauge tubes that remain out of calibration after cleaning should be replaced.

### 3.5. Gauge Tube Operating Principle

Operation of the Teledyne Hastings gauge tube is based on a low voltage AC bridge that heats a noble metal thermopile. A change in pressure in the gauge tube changes the molecular collision rate and therefore the thermal conduction of the gas surrounding the thermopile. This results in a temperature shift in the AC heated thermocouples and a corresponding change in their DC output, which varies inversely with pressure changes.

### 3.6. Linear Output Selection

The Digital CVT will be set for linear or nonlinear analog output at the factory. The customer may change the Digital CVT unit from its current linear or nonlinear configuration by rearranging the jumper settings of J24, located internally next to Pins 1 & 2 of the Terminal Block, to match the figure below for the desired analog output. Do not confuse J24 with the tube selection jumper described in the following section.

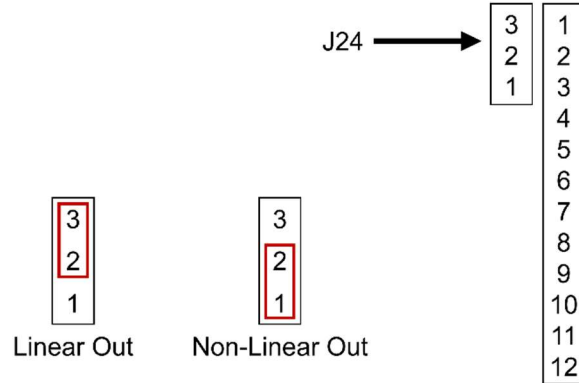

During linear output configuration, the customer may change the output voltage to 0-10V, 0-5V, 0-1V, 0-20mA, or 4-20mA linear full scale. Refer to sections 3.10 LINEAR OUTPUT CALIBRATION and 3.14.4 LINEAR COMMANDS for linear output calibration and commands.

### 3.7. Tube Selection

The Digital CVT can be setup to operate with a Hastings DV4, DV5, DV6 or DV33D vacuum gauge tube. There is a jumper located on the rear panel, which will select the desired tube if using a DV4 or DV6 tube. This jumper has no effect if the instrument is configured for a DV5 or DV33D tube.

Normally the Digital CVT will arrive from the factory configured for the tube type specified by the customer order. However, if the system pressure range changes and a different tube type will now be used, the tube type can be changed by moving the jumper position. The tube calibration procedure in section 3.8 must be performed after changing the tube type.



**NOTE:** Complete removal of the jumper will be interpreted by the internal processor as the DV-4 configuration. Both the DCVT-5 and DCVT-33 instruments will read properly in the DV-4 or DV-6 jumper configuration; therefore, no jumper arrangement is needed for the Digital CVT-5 or Digital CVT-33. Also, while in field, it is not possible to change a DV-4 or DV-6 to a DV-5.

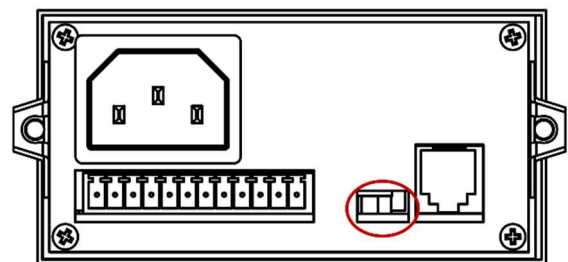
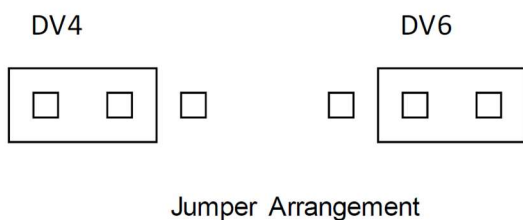

## 3.8. Calibration Procedure



NOTE: Once calibration is complete, the calibration data is permanently stored in nonvolatile memory. a loss of power will not erase the calibration data. to erase the calibration data, refer to section 3.8.1

### 3.8.1. Preparation

- Plug in DV-4, DV-5, DV-6 or DV-33 gauge tube. Leave tube at atmospheric pressure.
- Plug the Digital CVT power supply into an outlet providing 90 -250 VAC, 50/60 Hz.
- CLEAR out any previously entered calibration data.
  - Using a pointed object, such as a ballpoint pen, press and hold the “ATM” push button located on the front panel until “CLR” appears on the digital display. The “ATM” button must be held in the pressed position approximately 5 seconds before data is cleared and “CLR” is displayed.
- Once “CLR” is displayed any previously entered data has been deleted.



NOTE: tube must be at atmosphere to properly set the high end.

### 3.8.2. Set High End

Press “ATM” push button until “Set” appears. The high-end setting is now set.



NOTE: the low end can be adjusted by either bringing the system to a known vacuum or by using a Hastings reference tube.

### 3.8.3. Set Low End with Vacuum System

- Set system to known vacuum.
- Turn the “VAC” pot on front panel until the known vacuum is displayed on the digital display
  - If known vacuum is below 1 mTorr for DV-4, DV-6, and DV-33, or below 0.1 mTorr for DV-5, set the display to zero.
- The low end is now adjusted.

### 3.8.4. Set Low End with Reference Tube

- Connect a Teledyne Hastings reference tube.
- Turn the “VAC” pot until the value printed on the Teledyne Hastings reference tube is displayed on digital display.
- THE LOW END is now adjusted. See the table below to choose the appropriate reference tube with the Hastings gauge tube.

Reference Tube	Gauge Tube
DB-16D	DV-4
DB-17	DV-33
DB-18	DV-5
DB-20	DV-6



NOTE: If re-calibration is required you must first repeat section 3.8.1.

### 3.8.5. Multiple Tubes

If several tubes are to be read and re-calibration for each tube is not desired, you may clear the calibration data (3.8.1) and only adjust the low end setting once. If this course of action is chosen, a loss of accuracy will be noticed on the high end.

## 3.9. Set Relay Trigger Points

The DCVT provides 2 relays for process control. Each relay has a normally-open (NO), a common (Com) and a normally-closed (NC) contact available through the terminal block on the rear of the instrument. The pin-out is shown in section 2.1. Each relay operates independently from each other. Each relay will be energized whenever the pressure measured by the vacuum tube is less than the value that has been set for each relay. The relay setpoints can be read or changed locally using front panel controls or remotely through the serial port. Upon loss of power the DCVT relays will indicate a high-pressure condition.

### 3.9.1. Hysteresis

There is a small amount of hysteresis present in the relay trigger point to prevent excessive relay switching if the system pressure is close to a setpoint. The relay will energize exactly on the setpoint, but it will de-energize at approximately 1% of reading above the setpoint.

### 3.9.2. Reading / Changing Setpoints Locally

To view and change the setpoint for relay #1 using the front panel, press the switch next to the SP1 designator. The display will indicate the pressure value that is currently set on the potentiometer next to the SP1 designator. While holding the switch, adjust the potentiometer until the desired pressure is indicated on the display. When the switch is released, this pressure value will be stored as the setpoint for relay #1 and the instrument will return to normal pressure indication. Relay #2 can be set similarly using the controls next to the SP2 designator.



**NOTE:** If the setpoint had been set remotely via the serial port, the display will not indicate this remotely set value in setpoint adjust mode and the new locally set value will override the previous setpoint value.



**NOTE:** Whenever the appropriate setpoint switch is pressed and released the current setpoint will be changed to the value currently set by the potentiometer regardless of the any changes made remotely. Rotating the potentiometer while the switch is not pressed will not affect the setpoint, however the next time the switch is pressed the setpoint will change to the rotated value.

### 3.9.3. Reading / Changing Setpoints Remotely

While the instrument is in the setpoint adjust mode it cannot monitor the pressure at the vacuum tube and relays will not be set/reset if the pressure changes until the switch is released. To change the relay setpoints without losing the display functionality, the setpoint value can be read and changed remotely through the serial port.

### 3.9.4. Locking Relays On or Off

The relay switching can be prevented by setting the setpoint above or below the pressure range of the vacuum tube. Setting the setpoint to a negative value will keep the relay de-energized and setting the setpoint to high value will keep the relay energized at all times.

## 3.10. Linear Output Calibration

The DCVT linear output voltage will be set and calibrated at the factory per the customer's requested configuration. However, the customer may change the output voltage to 0-1V, 0-5V, 0-10V, 0-20mA, or 4-20mA linear full scale.

### 3.10.1. Setup

1. Connect the RJ12 (6P6C) connector from the back panel of the DCVT to a 9-pin computer serial port (#CB-RS232-RJ12).
  - i. Open HyperTerminal or another serial communications terminal program.
  - ii. Refer to section 2.3 for specific serial communication settings.
2. Ensure jumper J24 is configured for Linear Analog Output (see 3.6).
3. Connect a multimeter to pins 1 and 2 of the Terminal Block of (see 2.1).
  - i. If current signal is desired, a load resistor may be connected to pins 1 and 2, and the multimeter can measure the voltage across the load (see 2.4.3). Consider the expected voltage readings based on the load resistance and current scale setting (for  $R_L=250$ , 0mA = 0V, 4mA = 1V, 20mA = 5V).

### 3.10.2. Procedure

Before beginning this procedure, become familiar with the serial commands in 3.14.4.

1. Select the desired linear output range (e.g., Sending D10<CR> sets the output range to 0 - 10 VDC).
2. Connect a calibrated multimeter to the linear analog out conductors of the DAVC cable. The negative lead should be connected to the violet conductor (Pin 6) and the positive lead should be connected to the red conductor (pin 11).
3. Be certain to set the scale of the multimeter to the range that you have selected.
4. Send the DAZ<CR> command. The multimeter reading should be close to zero. To dial in on zero volts, first send the DZ<CR> command to find out what the current setting is. Then use  $DZ=\{m.dd\}E\{+e\}<CR>$  command and trial-and-error to get as close to zero volts as possible.
5. After achieving a close approximation to zero volts, send the DZW<CR> command to lock in any changes. If the unit is powered down before sending the DZW command, the unit will revert to the original setting on start up.
6. Send the DAS<CR> command. The multimeter should read a value close to the high end of the range that you selected. If 0 - 10 volts was selected, the meter should read very close to 10.000 volts. To tweak the DAC span voltage, first send the DS<CR> command and record the returned value. Use the command  $DS=\{m.dd\}E\{+e\}<CR>$  to alter this value until 10.000 volts is achieved.
7. After achieving a close approximation to the selected span value, send the DSW<CR> command to lock in any changes. If the unit is powered down before sending the DSW command, the unit will revert back to the original setting on start up.



**NOTE:** When adjusting the span value using the "DS=" command, the starting adjustment value should begin around "6000-7000" for 1v range, "32000-33000" for 10v and 5v ranges, and "22000-23000" for the 0-20ma and 4-20ma range.

### 3.11. Analog Output Interpretation

#### 3.11.1. Non-Linear Analog Output Interpretation

The DCVT has a 0-1 V analog output signal available on pins 1 and 2 of the terminal block. This signal is equal to an amplified tube millivolt signal. The following signal is NOT linearly proportional to the indicated pressure. Output of 1 volt will correspond to a system pressure that is less than 1 mTorr. Increasing pressure will be indicated by a decreasing voltage.

The voltage signal can be mapped to a pressure value by using the following equation.

$$P = \frac{a+cV+e}{1+bV+dV^2}, \quad V = \text{Tube Output Voltage}, \quad P = \text{Pressure in Torr for DV4, DV5, DV33, and mTorr for DV6}$$

Term	DV4	DV5	DV6	DV-33
a	-5.10184	-0.25948	-1623.22	-0.687519
b	-6.91233	-42.23869	-58.0442	-10.54539
c	-4.4943	-2.92598	-11732.2	-7.22733
d	-6.30995	-256.9951	-130.397	-52.55145
e	9.563177	3.18016	13338.17	7.905523

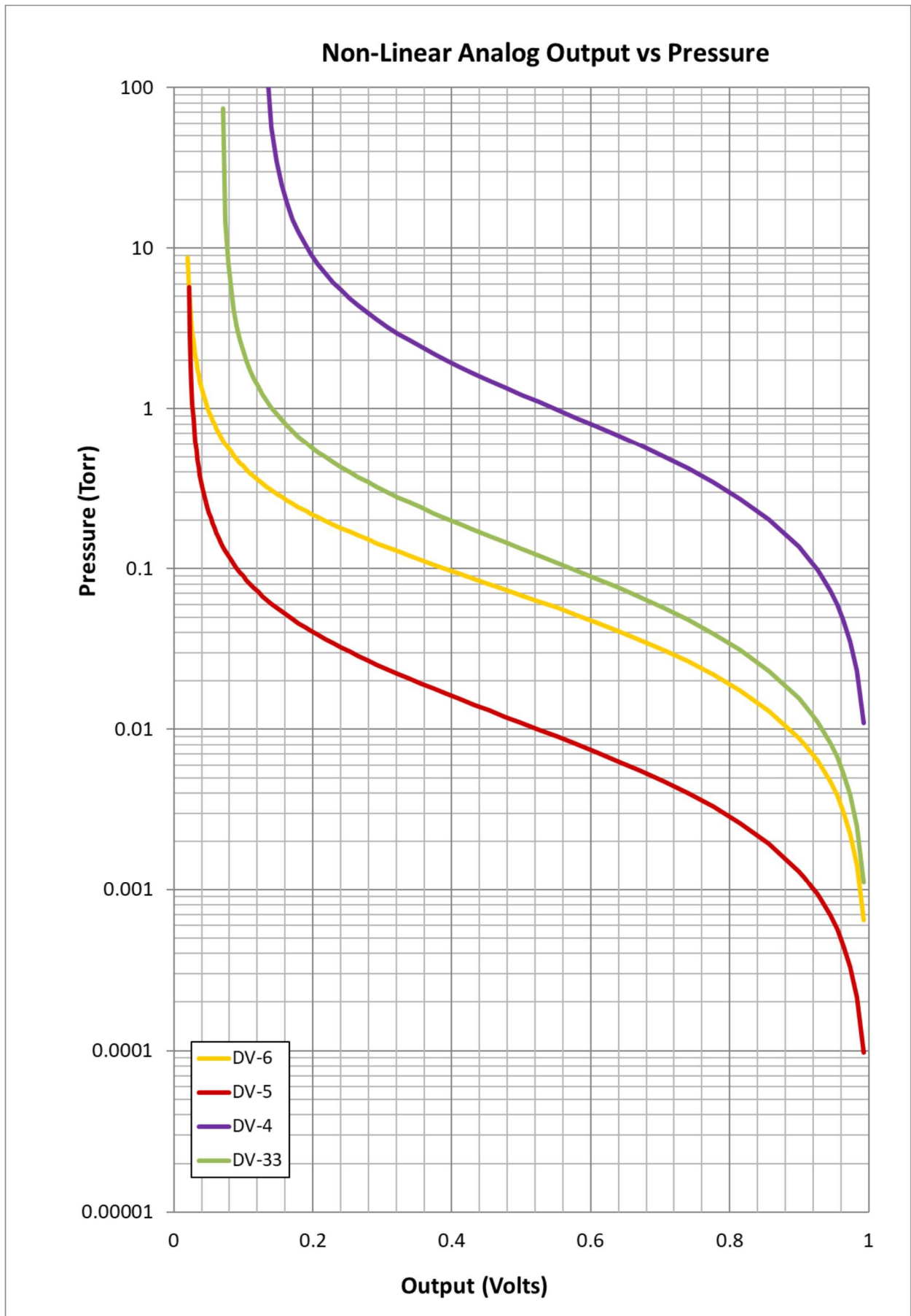

### 3.11.2. Linear Output Interpretation

The Linear DCVT provides voltage span values of 0-1V, 0-5V, 0-10V, 0-20mA, and 4-20ma. These analog output signals are available on pins 1 and 2 of the terminal block. This signal is equal to an amplified tube millivolt signal. The following signals are linearly proportional to their indicated voltages. Increasing pressure will be indicated by an increasing voltage.

The pressure value can be mapped to a voltage signal by using the following equation.

$$S = \left( \frac{P}{P_{max}} \cdot S_{span} \right) + S_{offset}$$

$S$  = Tube output signal (voltage or current),  $P$  = pressure in Torr for DV4, mTorr for DV5, DV6, DV33

$P_{max}$  = Max pressure value in tube range (20 Torr, 100 mTorr, 1000 mTorr),  $S_{span}$  = Output span value

$S_{offset}$  = Signal offset value (only used for 4 – 20 mA)

Term	0-1 V	0-5 V	0-10 V	0-20 mA	4-20 mA
$P_{max}$	Table in 1.1				
$S_{span}$	1	5	10	20	16
$S_{offset}$	0				4

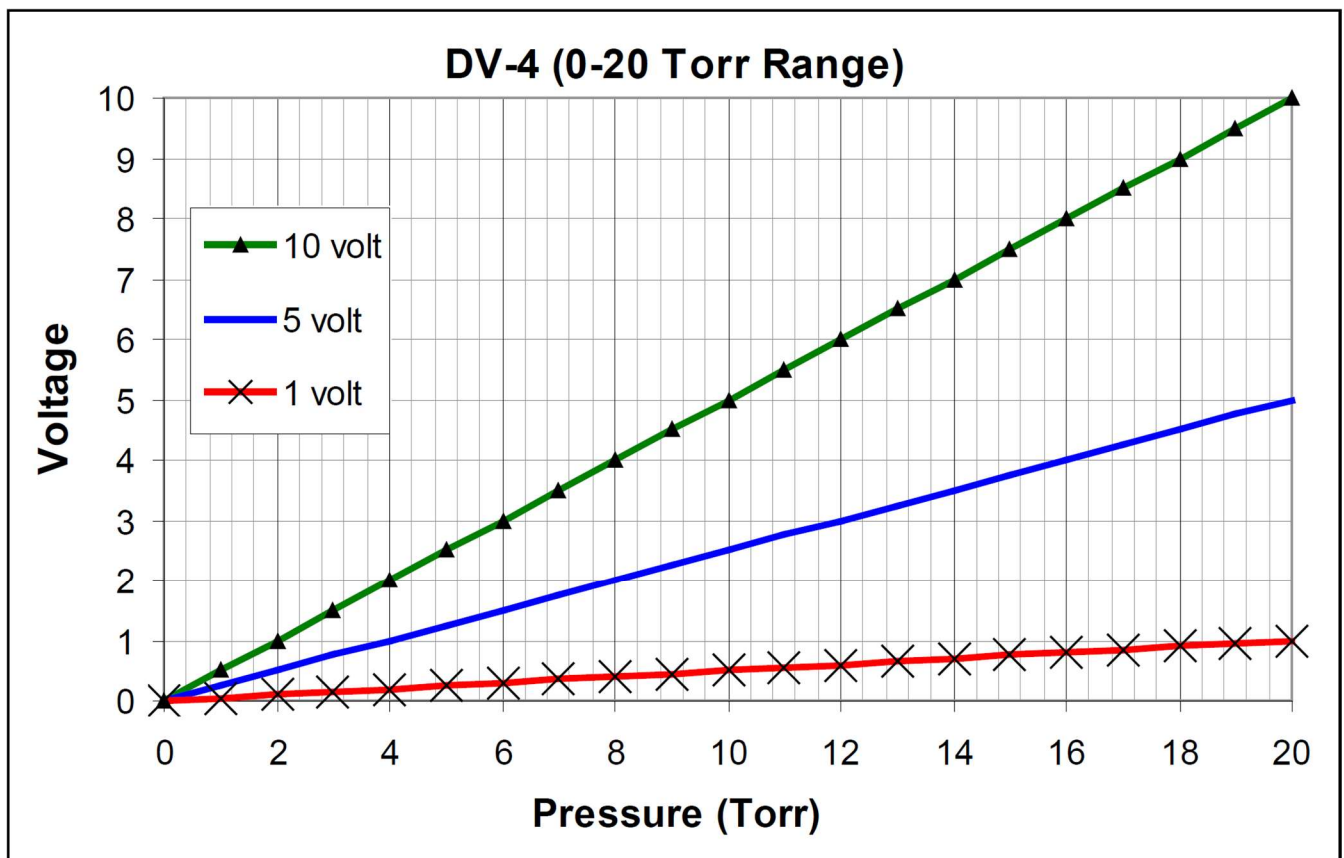

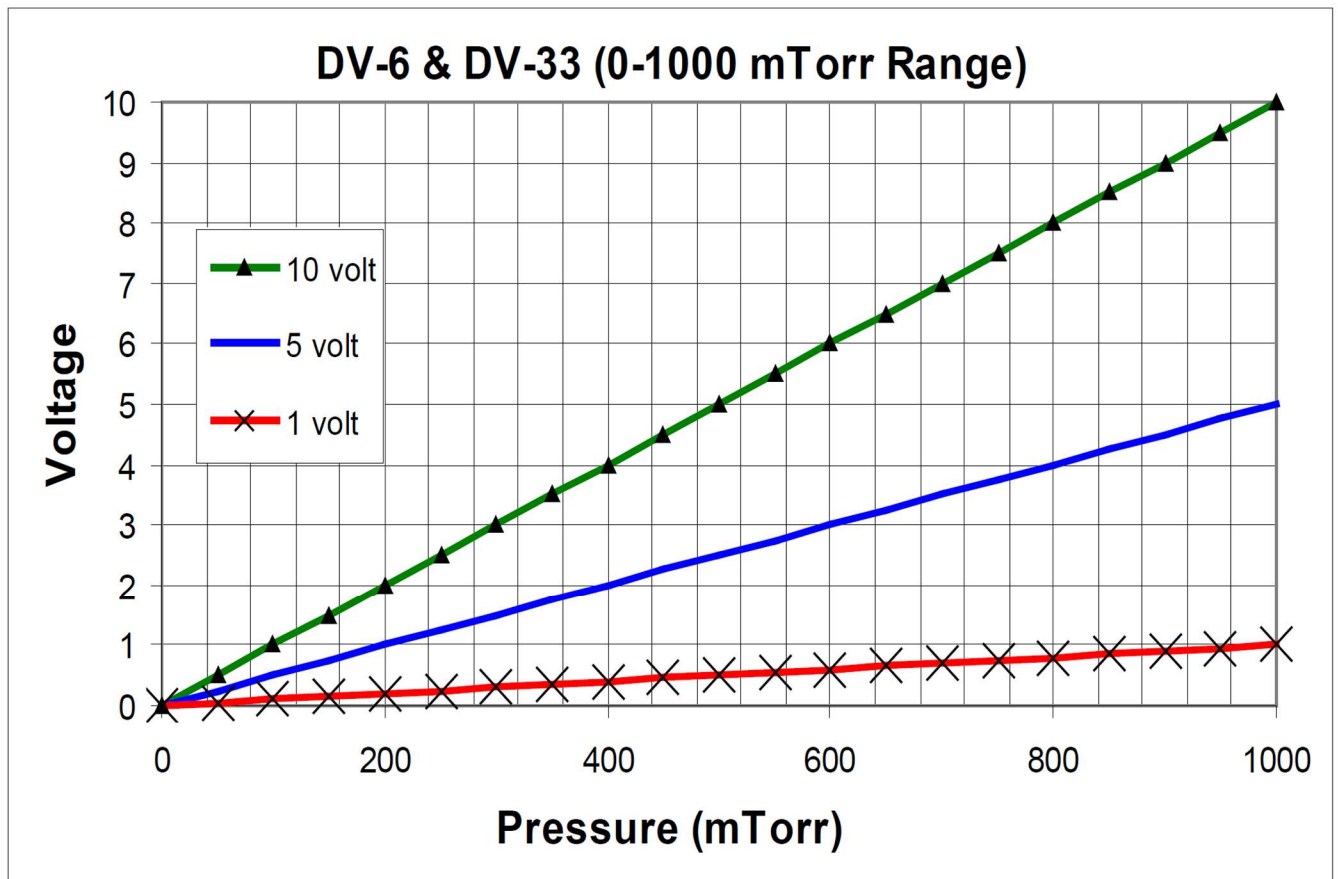
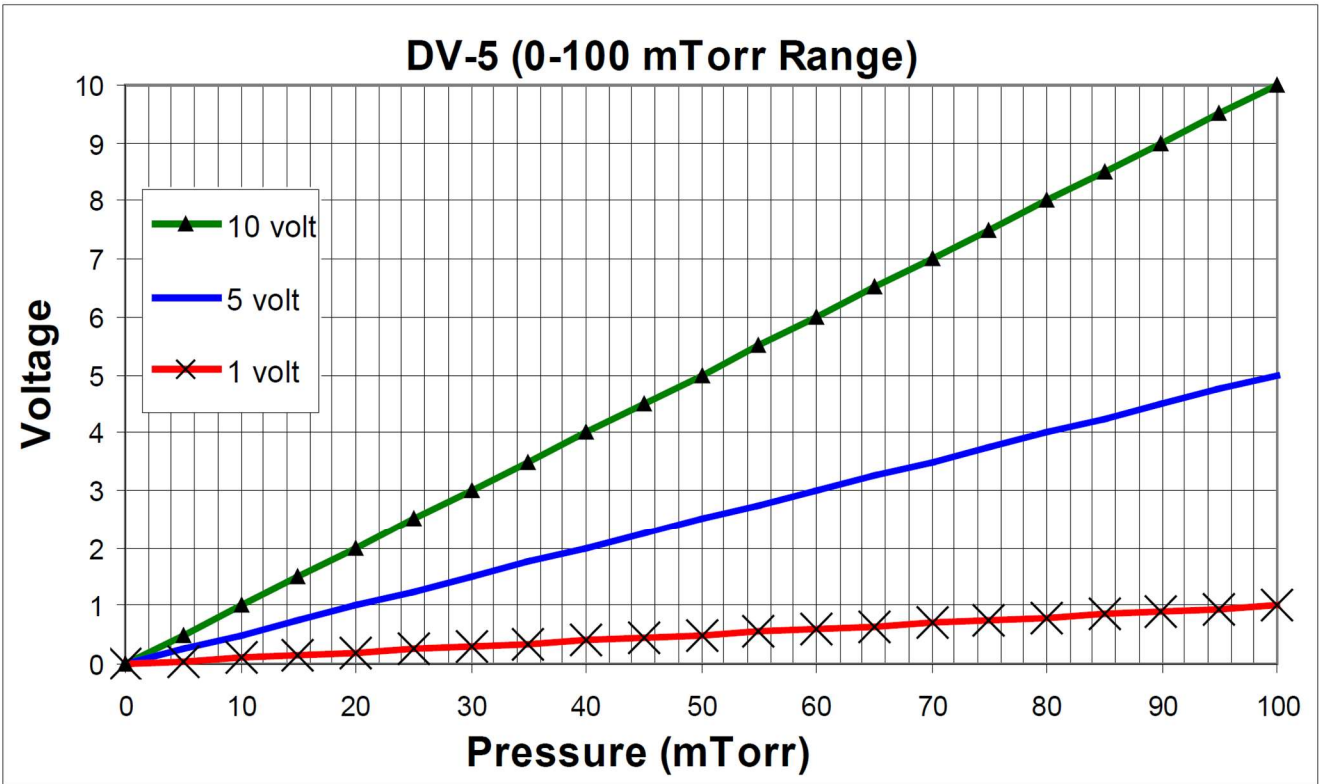

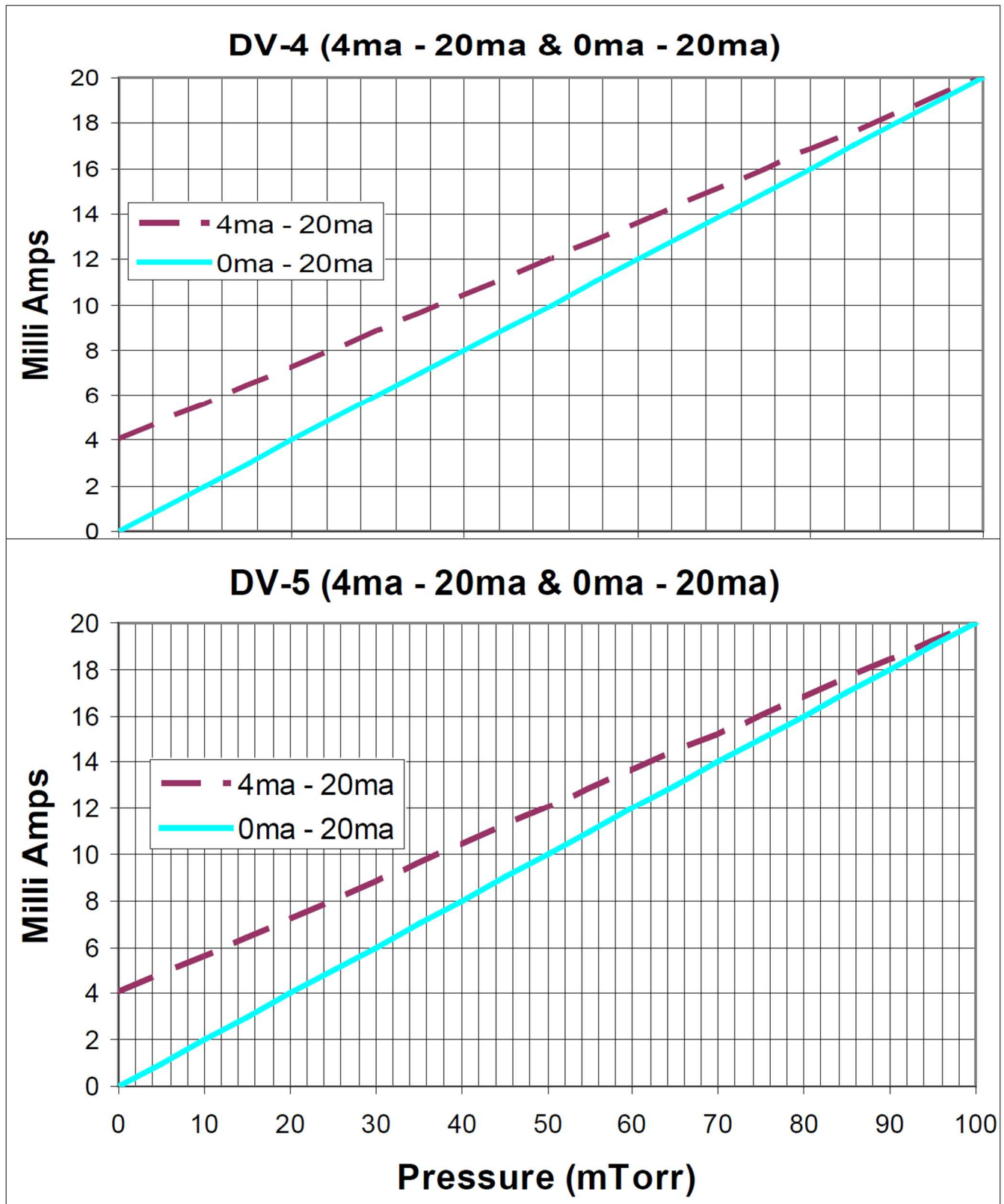

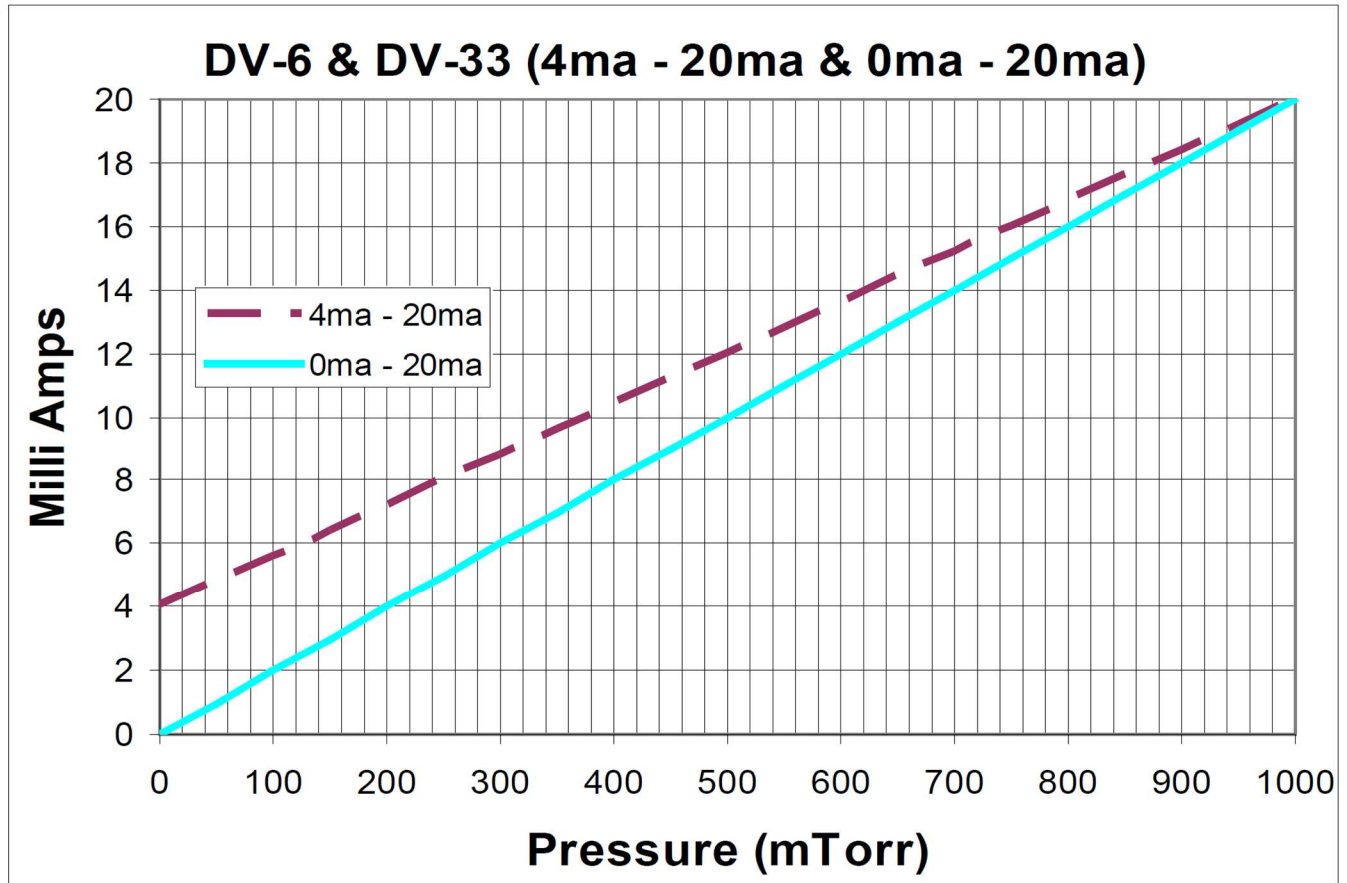

### 3.12. Pressure Units

The DCVT will arrive configured per customer order for one of these 3 possible pressure unit settings: Torr, mbar, Pascal. When setup at the factory the front panel overlay will indicate the proper units. However, the units can be changed in the field with a digital command over the serial interface. If changed in the field, the units shown on the overlay will not match the units of the displayed pressure. The pressure indication received serially will always report in the base of the selected units using scientific notation.

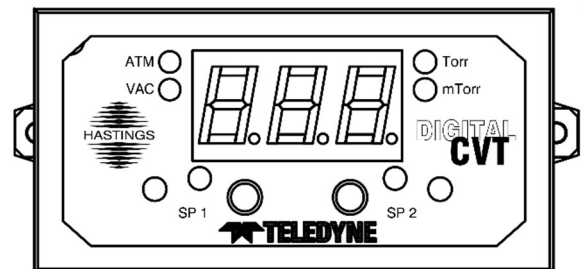

Since the DV4, DV5, and DV6 tube have a different pressure range, a different multiplier of each pressure unit is required to be able to display both tube types on the same 3-digit display. The top LED will light when in the DV-4 mode and it will indicate that the larger version of the base pressure unit is active. When a DV-5 or DV-6 tube is being used, the bottom LED will light and indicate that the smaller version of the pressure unit is presently active as shown in the table below.

Instrument	Pressure Units	Base Multiplier	Display Units	RS232
DV-4	torr	1	Torr	U1
	pascal	100	hPa	
	millibar	1	mbar	
DV-5	torr	0.001	mTorr	U2
	pascal	0.1	dPa	
	millibar	0.001	ubar	
DV-6 & DV-33	torr	0.001	mTorr	U3
	pascal	0.1	dPa	
	millibar	0.001	ubar	

## Digital CVT Instruction Manual

To convert the value given by the LED display to the given base unit, multiply the displayed value by the appropriate base multiplier.

As an example, if a DV-6 version of a DCVT is configured for Pascal and is displaying 543 then the current pressure is  $543 \times 0.1 = 54.3$  Pascal. In this case the serial port would report the pressure as "Pa: 5.43000e+1 Pascal<CR>".

If a DCVT-6 is configured for mbar and is displaying 543, the current pressure is  $543 \times 0.001 = 0.543$  mbar. In this case, the serial port would report the pressure as "Pa: 5.43000e-1 mbar<CR>". To convert mbar to bar multiply by 0.001. (Ex.  $0.543 \times 0.001 = 0.000543$  bar)

### 3.13. Thermal Coefficient

The Digital CVT generates an AC heating voltage using an internal transformer. This heating voltage is supplied to the vacuum tube to warm up the thermocouples to measure the pressure. As the ambient temperature increases or decreases, the internal resistance of the copper winding in the transformer also changes. This resistance change also changes the AC heating voltage that the vacuum tube receives. This also changes the pressure reading slightly. The typical rate of change for both the DV-4 and DV-6 are given below:

DV-6 0.06 mTorr/°C + 0.09% of reading/°C

DV-4 0.9 mTorr/°C + 0.03% of reading/°C

Increasing the temperature will cause the pressure readings to increase, while decreasing temperature will cause the pressure readings to decrease. The instruments are initially adjusted at an ambient temperature of approximately 22°C. This effect can be corrected by adjusting the low pressure reading at the operating ambient temperature. The specified rate of change does not include any changes due to thermal effects on the vacuum tube or actual changes in pressure that occur in a vacuum system during temperature excursions.

### 3.14. Digital Communications

Communication with the serial interface of the Digital CVT is via an ASCII data string. The command message consists only of a command string and the terminator. If all components of the ASCII data string are valid, the command will be accepted and executed.

#### 3.14.1. Command Syntax

In the following examples of syntax codes, the special characters are explained:

The characters in square brackets [ ] represent a command string, either upper- or lower-case command characters accepted. All characters must follow each other in the string with no spaces or other characters.

The characters within wavy brackets { } contain choices for the appropriate command.

The characters within the symbols < > are the common abbreviations for the one-digit ASCII control codes which they represent, (e.g. <CR> represents carriage return).

When entering more than one command in the same data string, they must be separated by a comma.

All command strings must be followed by the terminator character (carriage return <CR>, also known as ENTER).

When a lower-case character is present in an example it represents an option.

Character	Description	Valid Inputs
m	Most significant digit of Mantissa	1-9
d	Decimal Digit	0-9
e	Exponent	0-5
<CR>	CMD Terminator, (carriage return)	N/A

### 3.14.2. Interrogation Commands

Command Description	Format	Sample Response
Get Current Pressure	P<CR>	Pa: 1.23456e+0 Torr<CR>
Get Output Voltage	U<CR>	Vavg: 1.23456e-1 Volts<CR>
Get Relay #1 Setpoint	S1<CR>	SP1: 1.0240e-2 mbar<CR>
Get Relay #2 Setpoint	S2<CR>	SP2: 4.3639e-2 Pascal<CR>
Get Relay Status	RS<CR>	0,R1:OFF,R2:OFF<CR>
Get Device ID	ID<CR>	Digital CVT<CR>
Get Sensor Type	ST<CR>	DV-6<CR>
Get Software Version #	V<CR>	Digital CVT 1.1.0 <CR>
Get Serial Number	SN<CR>	1023400012<CR>
Get User Data	UD<CR>	Text String<CR>

The “User Data” is a 10-digit text area reserved for the use by the customer for identification purposes. For example, “User Data” could be set to reply “Foreline #1”.

The setpoints may also be entered as a decimal number, e.g. [S1=0.760<CR>] will be same as entering [S1=7.60E-1<CR>].

When inputting setpoint data, it should be entered in the same Units of Pressure as the presently selected Units of Measurement (i.e., Torr, mbar or Pascal). The data is only checked to be a valid number with a one-digit exponent before being accepted. There are no limit checks on the data; the user is free to choose any value appropriate to his use of the instrument.

If the command syntax is not met or if the number is out of range, the Digital CVT will respond with the ASCII codes for <bell>?<CR>, and the command will be ignored.

### 3.14.3. Parameter Modification Commands

Command Description	Format	Result / Valid Range:
Set unit to Torr	U1<CR>	All subsequent values in Torr
Set unit to Pascal	U2<CR>	All subsequent values in Pascal
Set unit to Mbar	U3<CR>	All subsequent values in mbar
Modify User Data	UD=Text String<CR>	10 character maximum
Modify Relay#1 Setpoint	S1= {m.dd} E {+e} <CR>	1.00000e-9 to 9.99999e+9
Modify Relay#2 Setpoint	S2= {m.dd} E {-e} <CR>	1.00000e-9 to 9.99999e+9

### 3.14.4. Linear Commands

After switching to linear output operation (J24), some instrument calibration may be required. Refer to section 3.10 for calibration setup and procedure.

Command Description	Command	Notes:
1 Volt Range	D1	Selects 1 Volt DAC Range
5 Volt Range	D5	Selects +/-5 Volt DAC Range
10 Volt Range	D10	Selects +/-10 Volt DAC Range
0-20 mA Range	D0	Selects 0-20 mA DAC Range
4-20 mA Range	D4	Selects 4-20 mA DAC Range
Read Zero Value	DZ	Read the DAC Zero Value
Set Zero Value	DZ=	Set the DAC Zero Value
Store Zero Value	DZW	Store the DAC Zero Value
Read Span Value	DS	Read the DAC Span Value
Set Span Value	DS=	Set the DAC Span Value
Store Span Value	DSW	Store the DAC Span Value
Output Zero Value to DAC	DAZ	Output Zero Value to DAC
Output Span Value to DAC	DAS	Output Span Value to DAC
Output Pressure Value to DAC	DAP	Output Pressure Value to DAC

### 3.14.5. Linear Status Output

The DCVT will arrive configured per customer order for one of the 5 possible linear output ranges: 0-1V, 0-5V, 0-10V, 0-20mA, or 4-20mA. The “ST” command provides the customer the ability to view the currently selected DV-Tube and linear output range. The following table provides the RS232 communication output of each DV-Tube and linear output.

Instrument	Linear Output	“ST” CMD Response
DV-X	0-1Volt	DV-x 0-1Volt
	0-5Volt	DV-x 0-5Volt
	0-10Volt	DV-x 0-10Volt
	0-20ma	DV-x 0-20 mA
	4-20ma	DV-x 4-20 mA

Where X = 4, 5, 6, or 33 depending on which tube is in use.



**NOTE:** When the Digital CVT unit is set to non-linear configuration per Figure 4 in section 3.6 LINEAR OUTPUT SELECTION, only the DV-Tube type (DV-x) of the “ST” command response is valid.

### 3.14.6. Reset / Initialize Commands

Command Description	Format	Notes:
Software Reset	/ <CR>	Reset instrument
Autobaud	<ctrl-z><CR>	Match baud rate currently in use

The <ctrl-z> is entered by holding down the “Ctrl” key while pressing the “z” key when using terminal emulator program. This character has an ASCII code of 26 (decimal) and 1A (hexadecimal).

### 3.14.7. Device Status

When requested to transmit the relay status, the Digital CVT responds with a 3-part text string which is explained in the following:

0, R1: OFF, R2: OFF

1st part (before 1st comma) binary representation of the state of both relays:

0 = 0 + 0 = both relays off

1 = 0 + 1 = relay 2 - off, relay 1 - on

2 = 2 + 0 = relay 2 - on, relay 1 - off

3 = 2 + 1 = both relays on

2nd part and 3rd part describe textually the status of each relay.

R1: OFF = Relay 1 is de-energized; pressure is above the setpoint for Relay1.

R1: ON = Relay 1 is energized; pressure is below the setpoint for Relay1.

R2: OFF = Relay 2 is de-energized; pressure is above the setpoint for Relay2.

R2: ON = Relay 2 is energized; pressure is below the setpoint for Relay2.

## 4. Warranty and Repair

### 4.1. Warranty Repair Policy

See the company website for warranty information at:

<http://www.teledyne-hi.com>

### 4.2. Return Policy

See the company website for return information at:

<http://www.teledyne-hi.com>

Any product returned for either warranty or non-warranty repair must have been issued a Return Material Authorization (RMA) form.

RMA Forms may be obtained from the Calibration and Repair section of the Hastings Instruments website:

<http://www.teledyne-hi.com>



**WARNING:** Contaminated parts can be detrimental to health and environment. Ensure instruments are free of hazardous contamination prior to shipment.

#### Company contact information

TELEDYNE HASTINGS INSTRUMENTS

804 NEWCOMBE AVENUE

HAMPTON, VIRGINIA 23669 U.S.A.

ATTENTION: RMA # that has been issued for return

TELEPHONE (757) 723-6531  
1-800-950-2468

FAX (757) 723-3925

E MAIL [mailto:hastings\\_service@teledyne.com](mailto:hastings_service@teledyne.com)

INTERNET ADDRESS <http://www.teledyne-hi.com>

## 5. Drawings and Installation

The following sections show the outline dimensions, front and back panels, and mounting information for the Digital CVT (DCVT).

### 5.1. DCVT Outline Dimensions

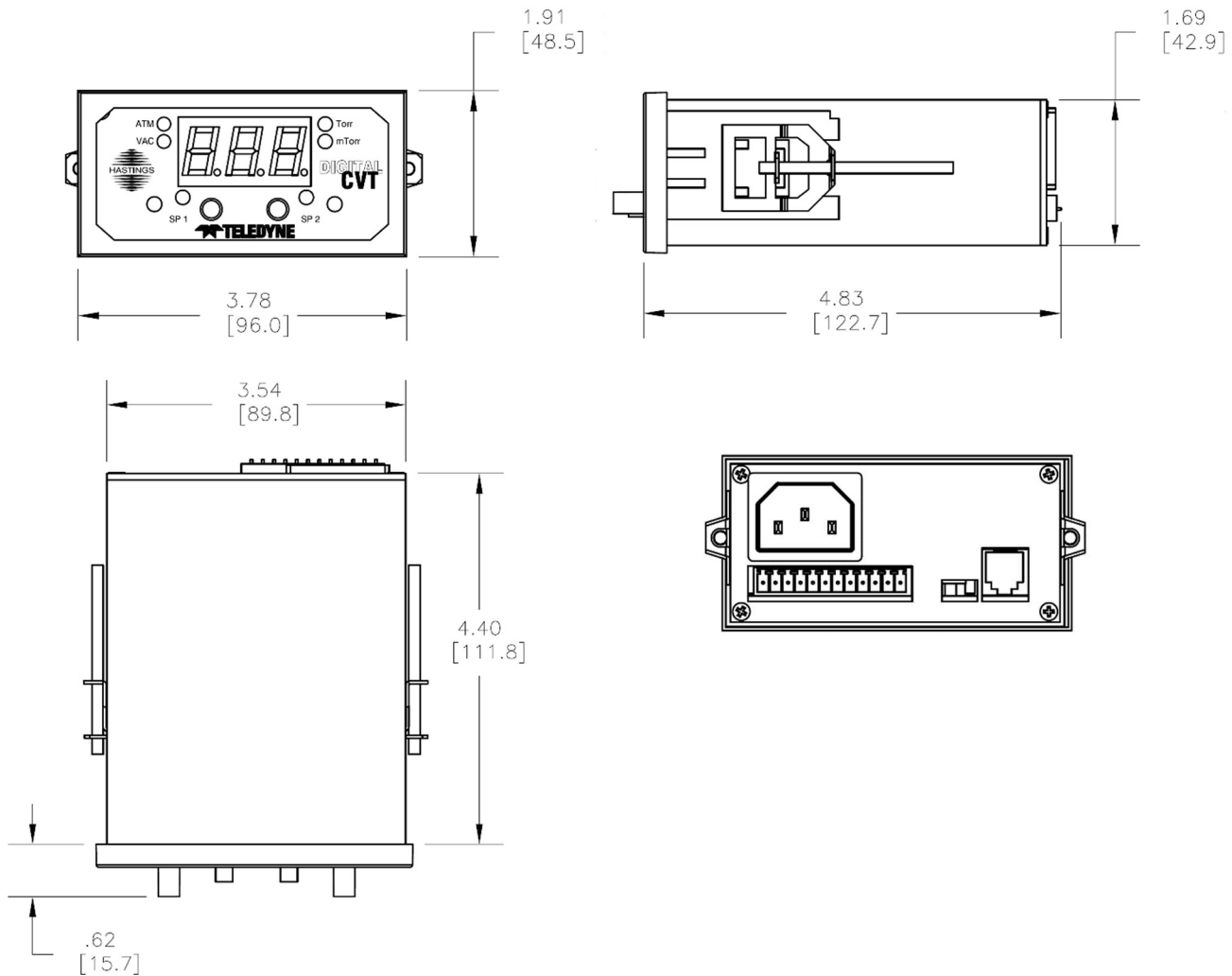

## 5.2. DCVT Front Panel

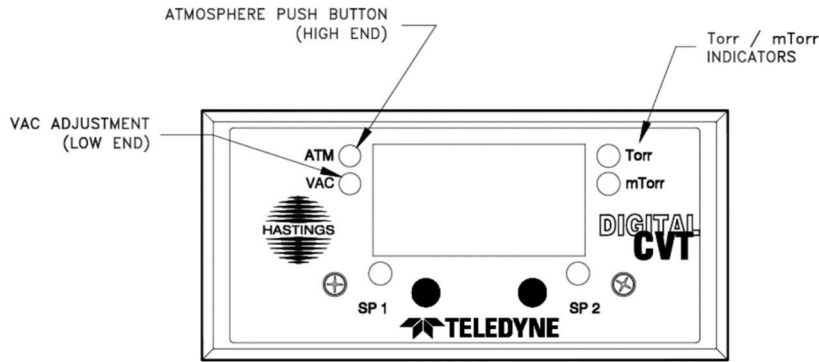

## 5.3. DCVT Back Panel

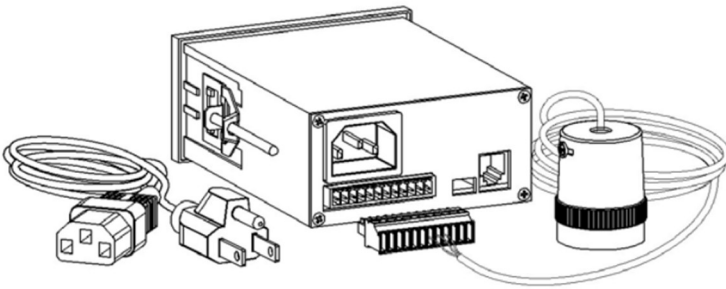

## 5.4. DCVT Mounting

Shut-off power to the panel. Install the Digital CVT through the panel cutout as shown in the illustration below. Attach brackets to the side of the case and tighten until the front of the case is snug against the instrument panel. Use the power cord supplied with the unit and follow local codes when connecting power source to the unit.

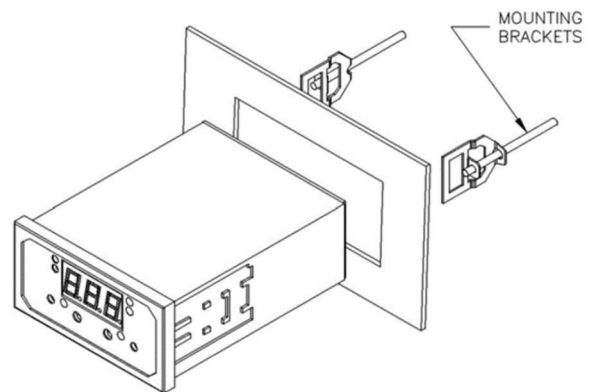
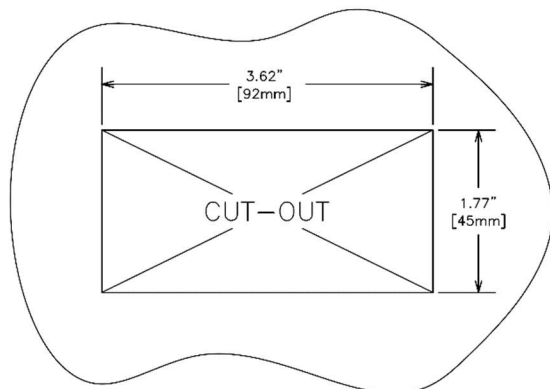

### 5.5. DCVT-33D Outline Drawings

TOP VIEW

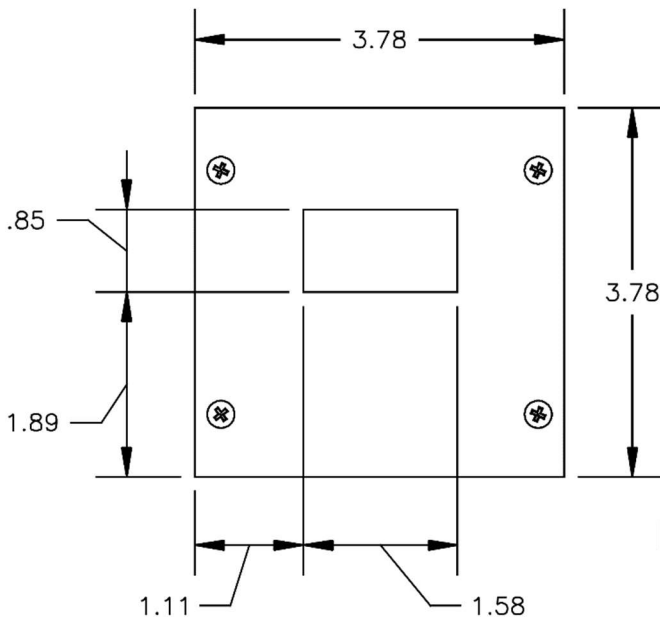
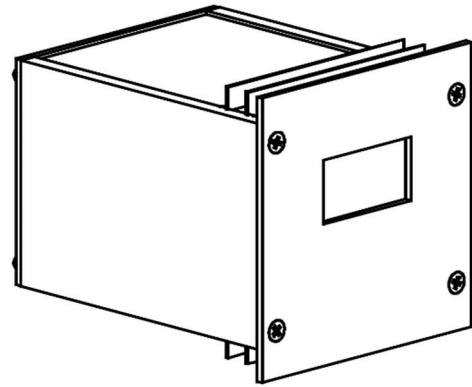
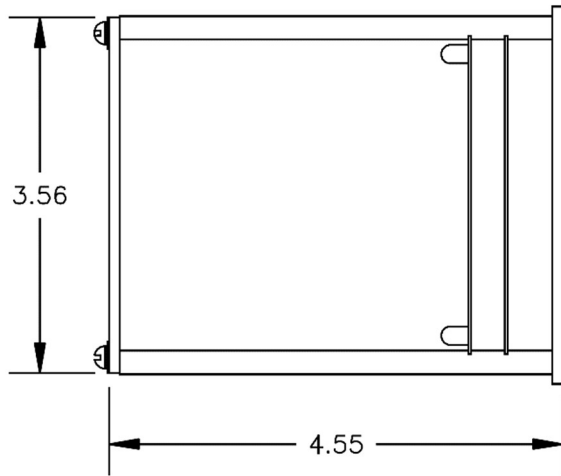

FRONT

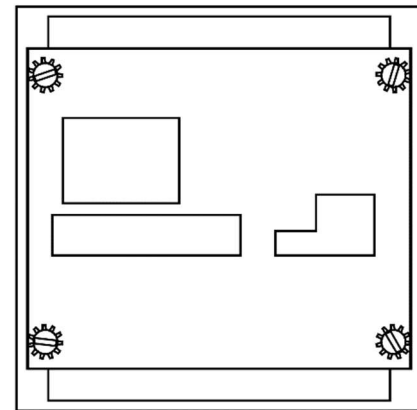

BACK

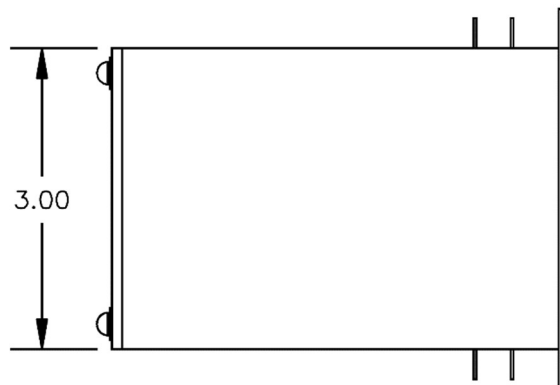

SIDE VIEW